

IT ATTENZIONE:

LA SICUREZZA DELL'APPARECCHIO E' GARANTITA SOLO CON L'USO APPROPRIATO DELLE SEGUENTI ISTRUZIONI; PERTANTO E' NECESSARIO CONSERVARLE.

EN WARNING:

THE SAFETY OF THIS FIXTURE IS GUARANTEED ONLY IF YOU COMPLY WITH THESE INSTRUCTIONS; REMEMBER TO CONSERVE IN A SAFE PLACE.

FR ATTENTION:

LA SECURITE DE L'APPAREIL N'EST GARANTIE QU'EN CAS D'UTILISATION CORRECTE DES INSTRUCTIONS SUIVANTES; IL FAUT PAR CONSEQUENT LES CONSERVER.

DE ACHTUNG:

DIE SICHERHEIT DES GERÄTES WIRD NUR DURCH SACHGEMÄSSE BEFOLGUNG NACHSTEHENDER ANWEISUNGEN GEWÄHRLEISTET; IHRE AUFBEWAHRUNG IST DESHALB SEHR WICHTIG.

NL OPGELET:

DE VEILIGHEID VAN DI ATOESTEL IS SLECHTS DAN GEGARANDEERD ALS INDIEN DE VOLGENDE INSTRUCTIES STRIKT WORDEN TOEGEPAST; DAAROM MOET MEN ZE OOK BEWAREN.

ES ATENCION:

LA SEGURIDAD DEL APARATO SE GARANTIZA SOLO CUMPLIENDO CUIDADOSAMENTE LAS SIGUIENTES INSTRUCCIONES; POR ELLO, ES NECESARIO CONSERVARLAS.

DA BEMÆRK:

SIKKERHEDEN VED BRUG AF ARMATURET KAN KUN GARANTERES, HVIS DISSE ANVISNINGER FØLGES; SØRG DERFOR FOR AT GEMME DEM.

NO ADVARSEL:

SIKKERHETEN TIL DETTE APPARATET GARANTERES KUN HVIS DU OVERHOLDER DISSE INSTRUKSJONENE; HUSK Å OPPBEVARE DEM PÅ ET TRYGT STED.

SV OBSERVERA!

UTRUSTNINGENS SÄKERHET KAN ENDAST GARANTERAS OM DESSA ANVISNINGAR RESPEKTERAS I DETALJ. SPARA DÄRFÖR DESSA ANVISNINGAR FÖR FRAMTIDA KONSULTATION.

RU ВНИМАНИЕ:

МЫ ГАРАНТИРУЕМ БЕЗОПАСНУЮ ЭКСПЛУАТАЦИЮ ИЗДЕЛИЯ ТОЛЬКО ПРИ СОБЛЮДЕНИИ СЛЕДУЮЩИХ ИНСТРУКЦИЙ; С ЭТОЙ ЦЕЛЬЮ НЕОБХОДИМО СОХРАНИТЬ ДАННУЮ БРОШЮРУ.

ZH 警告

为确保该装置安全，请遵守操作指示；并于安全场所放置。

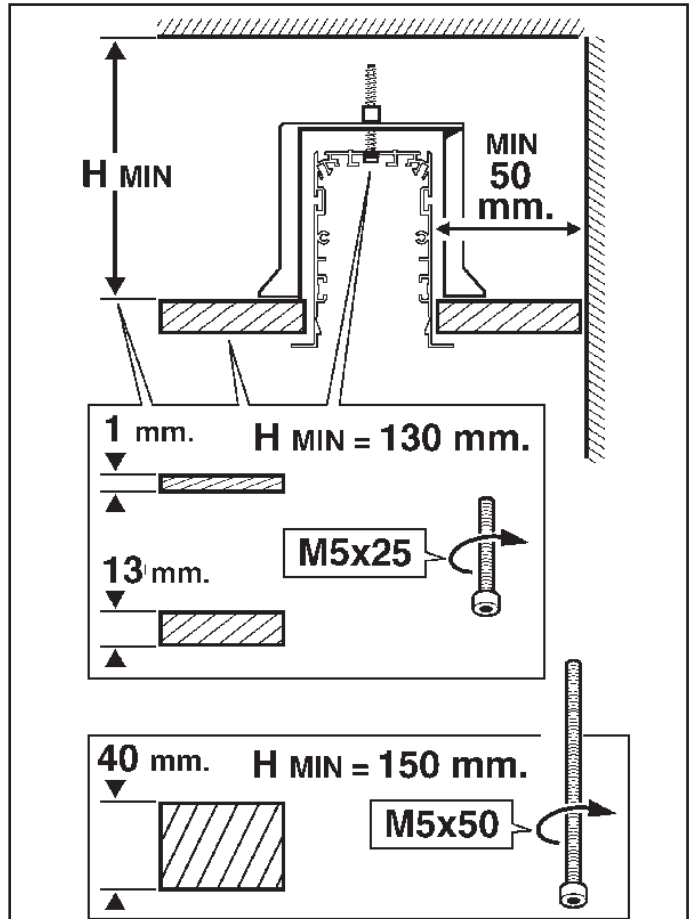

OPENING CALCULATION

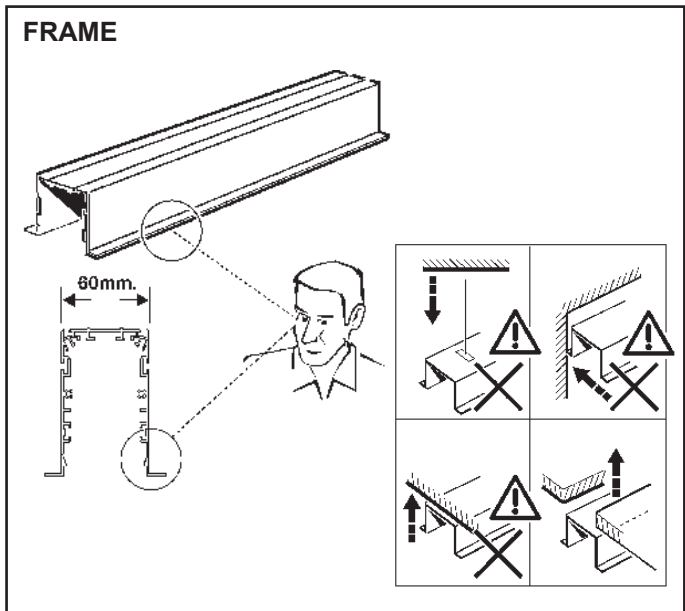
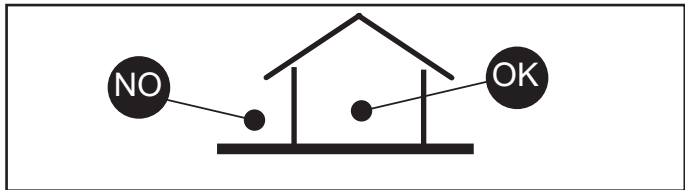
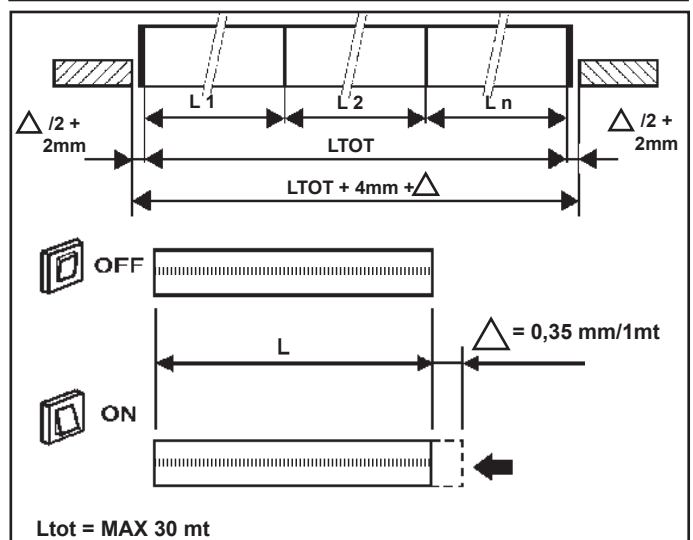
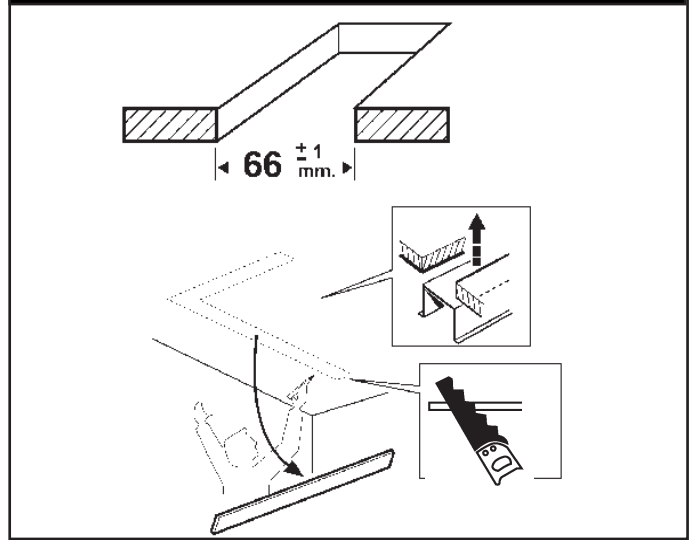

PRODUCT DIMENSIONS

ART.	L (mm)
QA84 - QB64 - QZ63 - QZ91	612
QA85 - QB65 - QZ64 - QZ92	1208
QA86 - QB66 - QZ65 - QZ93	2397
QA87 - QB67 - QZ66 - QZ94	3596
QA88 - QB68 - QZ67 - QZ95	898
QA89 - QB69 - QZ68 - QZ96	3596
QX47	1192
QX54	2384

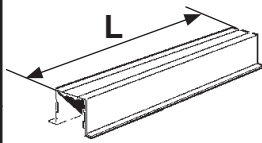

ART.	L (mm)
QB00 - QB01 - QB02 - QB03 QB32 - QB33 - QB34 - QB35 QB80 - QB81 - QB82 - QB83 QZ77 - QZ79 - QZ78 - QZ80 QZ81 - QZ83 - QZ82 - QZ84 R051 - R053 - R052 - R054	642 x 642

Non serrare a fondo
Do not tighten fully
Ne pas serrer à fond
Nicht vollständig festziehen
Niet geheel vast draaien
No atornille a fondo
Skrú ikkje helt i bund
Ikke trekk helt til
Dra inte åt till botten
Не закручивать до упора
请勿完全拧紧

**ACCESSORY
END CUP
ART. PB32 - MWP7**

Serrare a fondo
Tighten firmly
Serrer à fond
Fest einrasten
Goed aanschroeven
Enrosar en firme
Skrues i bund
Trek til godt
Dra åt till botten
закручивать до упора
完全拧紧

IT Per le posizioni di installazione, attenersi a quelle illustrate, eventualmente contattare la iGuzzini.

EN All installation positions must comply with those illustrated. In the event of any doubt, contact iGuzzini.

FR Pour les positions d'installation, se conformer aux positions illustrées ; contacter la société iGuzzini en cas de nécessité

DE Für die Einbaupositionen die Abbildungen beachten. Eventuell iGuzzini kontaktieren.

NL Houd u voor de installatieposities aan degene die zijn weergegeven. Neem eventueel contact op met iGuzzini

ES Respetar las posiciones de instalación ilustradas y, en caso de duda, contactar con iGuzzini

DA For installationspositioner skal man holde sig til de viste, og eventuelt kontakte iGuzzini

NO For installasjonsplassingene henviser vi til illustrasjonene, eller ta eventuelt kontakt med iGuzzini

SV Följ de angivna positionerna för installationen. Kontakta vid behov iGuzzini

RU При выборе положения для монтажа следует обратиться к проиллюстрированным либо обратиться в компанию iGuzzini

ZH 安装位置请参考图示，必要时也可联系iGuzzini



iN60 Led (MINIMAL) recessed application

IT Attenzione:

La sicurezza dell'apparecchio e' garantita solo con l'uso appropriato delle seguenti istruzioni; pertanto e' necessario conservarle.

EN Warning:

The safety of this fixture is guaranteed only if you comply with these instructions; remember to conserve in a safe place.

FR Attention:

La sécurité de l'appareil n'est garantie qu'en cas d'utilisation correcte des instructions suivantes; il faut par conséquent les conserver.

DE Achtung:

Die sicherheit des gerätes wird nur durch sachgemässe befolgung nachstehender anweisungen gewährleistet; ihre aufbewahrung ist deshalb sehr wichtig.

NL Opgelet:

De veiligheids van dit toestel is slechts dan gegarandeerd als indien de volgende instructies strikt worden toegepast: daarom moet men ze ook bewaren.

ES Atencion:

La seguridad del aparato se garantiza solo cumpliendo cuidadosamente las siguientes instrucciones; por ello, es necesario conservarlas.

DA Bemærk:

Sikkerheden ved brug af armaturet kan kun garanteres, hvis disse anvisninger følges; sørg derfor for at gemme dem.

NO Advarsel:

Sikkerheten til dette apparatet garanteres kun hvis du overholder disse instruksjonene; husk å oppbevare dem på et trygt sted.

SV Observera:

Utrustningens säkerhet kan endast garanteras om dessa anvisningar respekteras i detalj. Spara därför dessa anvisningar för framtida konsultation.

RU Внимание:

Мы гарантируем безопасную эксплуатацию изделия только при соблюдении следующих инструкций; с этой целью необходимо сохранить данную брошюру.

ZH 警告:

为确保该装置安全, 请遵守操作指示; 并于安全场所放置。

AR تحذير: لا يمكن ضمان سلامة هذا الجهاز إلا إذا التزمت بهذه التعليمات. يجب حفظها في مكان آمن.

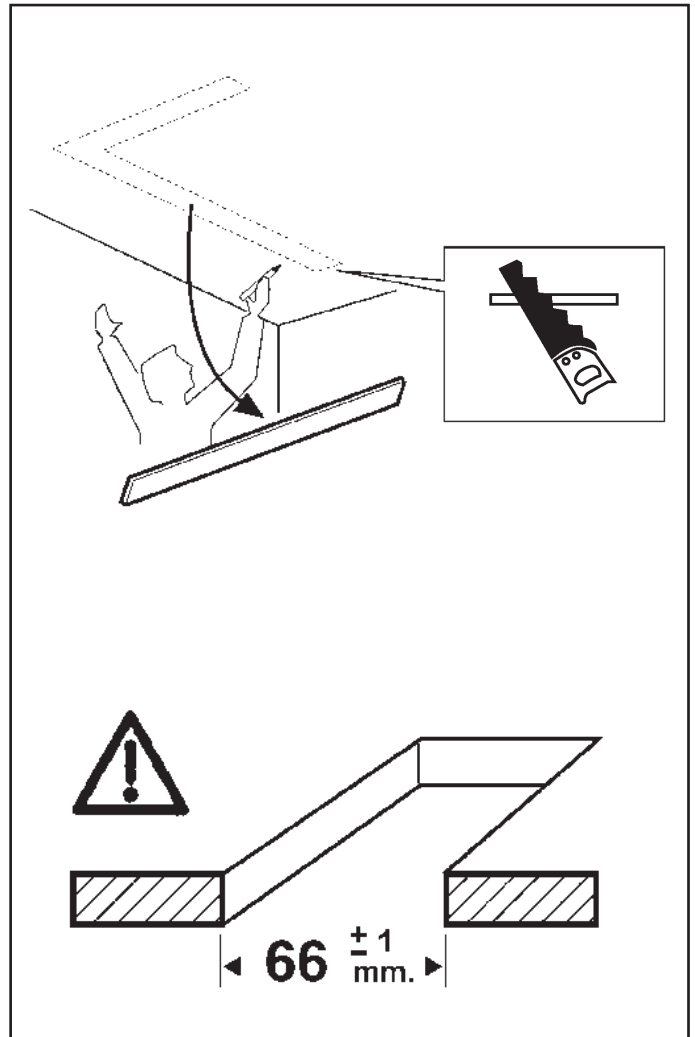

OPENING CALCULATION

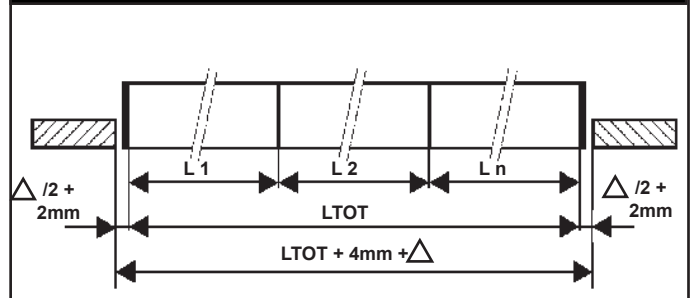

Ltot = MAX 30 mt



PRODUCT DIMENSIONS



ART.	L (mm)	P (mm)	A (mm)	
QA90 - QB70 - QZ57 - QZ85	612	212	200	2
QA91 - QB71 - QZ58 - QZ86	1208	500	354	2
QA92 - QB72 - QZ59 - QZ87	2397	800	399	3
QA93 - QB73 - QZ60 - QZ88	3596	980	328	4
QA94 - QB74 - QZ61 - QZ89	898	498	200	2
QA95 - QB75 - QZ62 - QZ90	3596	980	328	4
QX48	1192	500	346	2
QX55	2384	800	392	3

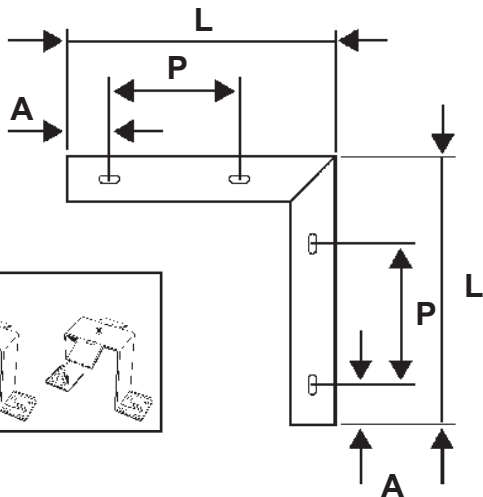

art. MWH6



ART.	L (mm)	P (mm)	A (mm)	
QB04 - QB05 - QB06 - QB07 QB36 - BQ37 - QB38 - QB39 QB84 - QB85 - QB86 - QB87 QZ69 - QZ70 - QZ71 - QZ72 QZ73 - QZ74 - QZ75 - QZ76 QZ97 - QZ98 - QZ99 - R050	642 x 642	250	200	4

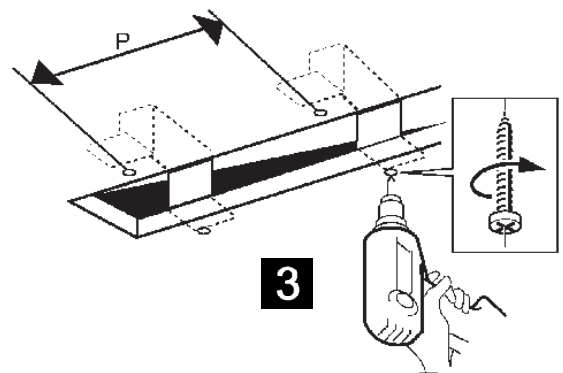
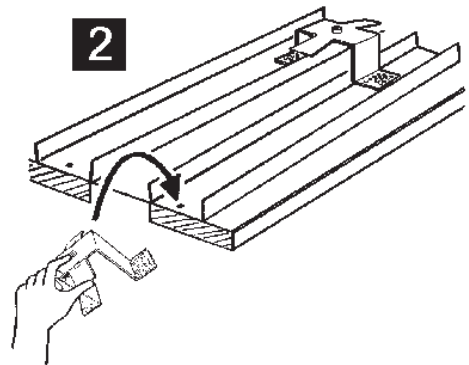

ACCESSORY
END CUP
ART. PB33 - MWP6



5

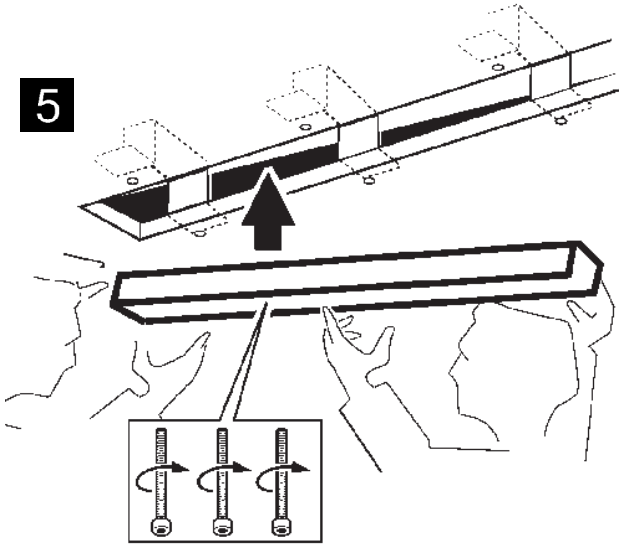

NO

OK

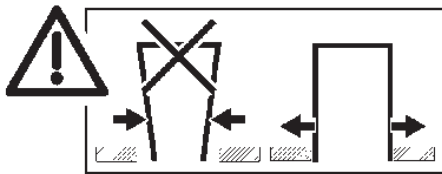

6



7

IT Utilizzare silicone di tipo acrilico (verniciabile)

EN Use silicone of acrylic type (paintable)

FR Utiliser du silicone acrylique (pouvant être peint)

DE Benutzen Sie (überstreichbares) Acryl

NL Gebruik een acrylsilicone (overschilderbaar)

ES Utilizar silicona de tipo acrilico (pintable)

DA Brug akrylsilicone (som kan lakeres)

NO Bruk silikon av akrylisk type (overmalbar)

SV Använd silikon av akryltyp (målningsbar)

RU Используйте силикон акрилового типа (под покраску)

ZH 使用丙烯酸類矽膠 (可塗漆)

AR

استخدم سيليكو اكريليك (قابل الطلاء)



9

10

IT Per le posizioni di installazione, attenersi a quelle illustrate, eventualmente contattare la iGuzzini.

EN All installation positions must comply with those illustrated. In the event of any doubt, contact iGuzzini.

FR Pour les positions d'installation, se conformer aux positions illustrées ; contacter la société iGuzzini en cas de nécessité.

DE Für die Einbaupositionen die Abbildungen beachten. Eventuell iGuzzini kontaktieren.

NL Houd u voor de installatieposities aan degene die zijn weergegeven. Neem eventueel contact op met iGuzzini.

ES Respetar las posiciones de instalación ilustradas y, en caso de duda, contactar con iGuzzini.

DA For installationspositioner skal man holde sig til de viste, og eventuelt kontakte iGuzzini.

NO For installasjonsplassingene henviser vi til illustrasjonene, eller ta eventuelt kontakt med iGuzzini.

SV Följ de angivna positionerna för installationen. Kontakta vid behov iGuzzini.

RU При выборе положения для монтажа следует обратиться к проиллюстрированным либо обратиться в компанию iGuzzini.

ZH 安装位置请参考图示，必要时也可联系iGuzzini.

AR في ما يتعلق بأوضاع التركيب، التزم بما هو موضح ومحدد، إذا دعت الضرورة اتصل ب iGuzzini



IT ATTENZIONE:

LA SICUREZZA DELL'APPARECCHIO E' GARANTITA SOLO CON L'USO APPROPRIATO DELLE SEGUENTI ISTRUZIONI; PERTANTO E' NECESSARIO CONSERVARLE.

EN WARNING:

THE SAFETY OF THIS FIXTURE IS GUARANTEED ONLY IF YOU COMPLY WITH THESE INSTRUCTIONS; REMEMBER TO CONSERVE IN A SAFE PLACE.

FR ATTENTION:

LA SECURITE DE L'APPAREIL N'EST GARANTIE QU'EN CAS D'UTILISATION CORRECTE DES INSTRUCTIONS SUIVANTES; IL FAUT PAR CONSEQUENT LES CONSERVER.

DE ACHTUNG:

DIE SICHERHEIT DES GERÄTES WIRD NUR DURCH SACHGEMÄSSE BEFOLGUNG NACHSTEHENDER ANWEISUNGEN GEWÄHRLEISTET; IHRE AUFBEWAHRUNG IST DESHALB SEHR WICHTIG.

NL OPGELET:

DE VEILIGHEID VAN DI ATOESTEL IS SLECHTS DAN GEGARANDEERD ALS INDIEN DE VOLGENDE INSTRUCTIES STRIKT WORDEN TOEGEPAST; DAAROM MOET MEN ZE OOK BEWAREN.

ES ATENCION:

LA SEGURIDAD DEL APARATO SE GARANTIZA SOLO CUMPLIENDO CUIDADOSAMENTE LAS SIGUIENTES INSTRUCCIONES; POR ELLO, ES NECESARIO CONSERVARLAS.

DA BEMÆRK:

SIKKERHEDEN VED BRUG AF ARMATURET KAN KUN GARANTERES, HVIS DISSE ANVISNINGER FØLGES; SØRG DERFOR FOR AT GEMME DEM.

NO ADVARSEL:

SIKKERHETEN TIL DETTE APPARATET GARANTERES KUN HVIS DU OVERHOLDER DISSE INSTRUKSJONENE; HUSK Å OPPBEVARE DEM PÅ ET TRYGT STED.

SV OBSERVERA!

UTRUSTNINGENS SÄKERHET KAN ENDAST GARANTERAS OM DESSA ANVISNINGAR RESPEKTERAS I DETALJ. SPARA DÄRFÖR DESSA ANVISNINGAR FÖR FRAMTIDA KONSULTATION.

RU ВНИМАНИЕ:

МЫ ГАРАНТИРУЕМ БЕЗОПАСНУЮ ЭКСПЛУАТАЦИЮ ИЗДЕЛИЯ ТОЛЬКО ПРИ СОБЛЮДЕНИИ СЛЕДУЮЩИХ ИНСТРУКЦИЙ; С ЭТОЙ ЦЕЛЬЮ НЕОБХОДИМО СОХРАНИТЬ ДАННУЮ БРОШЮРУ.

ZH 警告

为确保该装置安全，请遵守操作指示；并于安全场所放置。

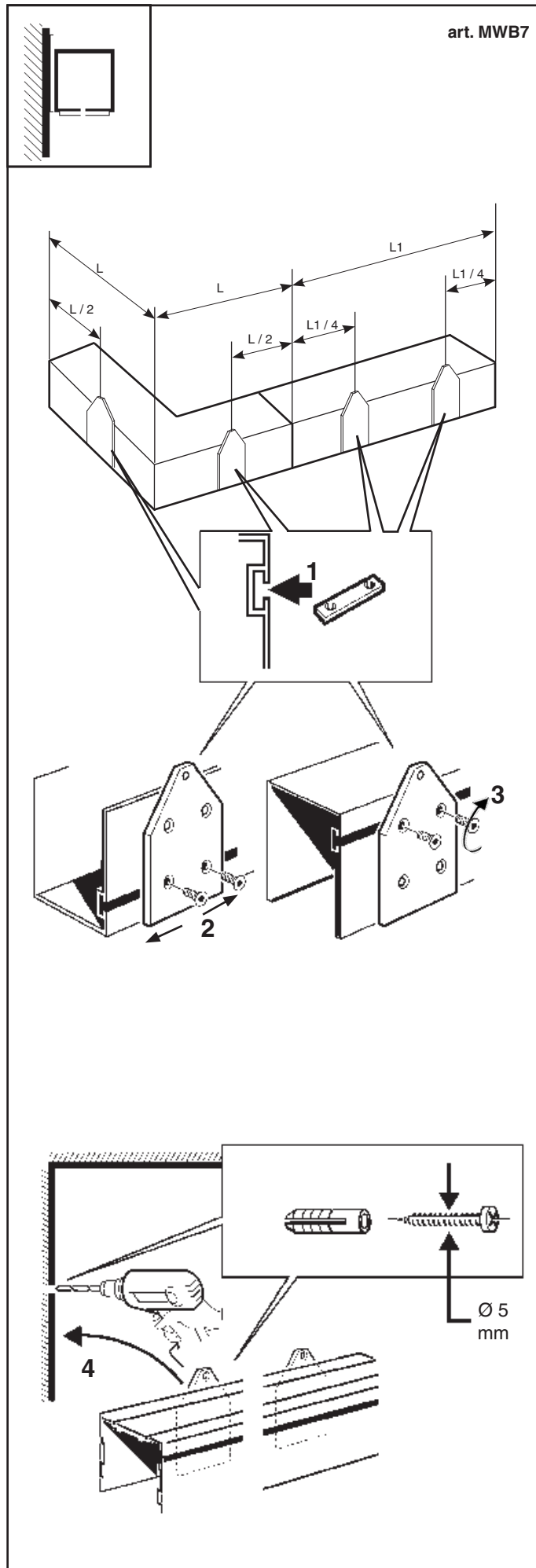
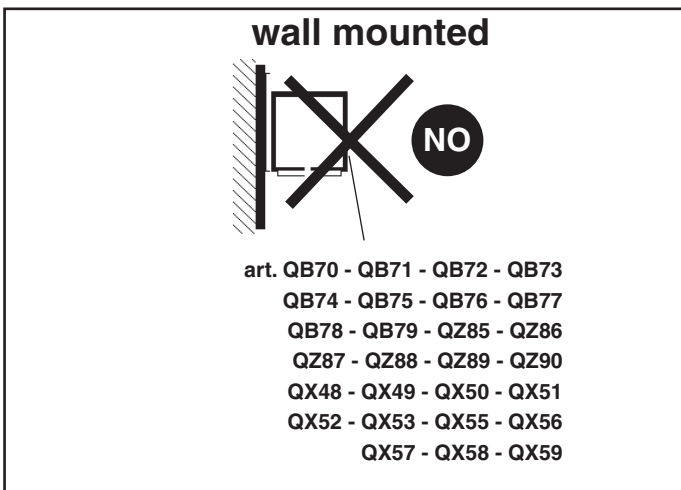
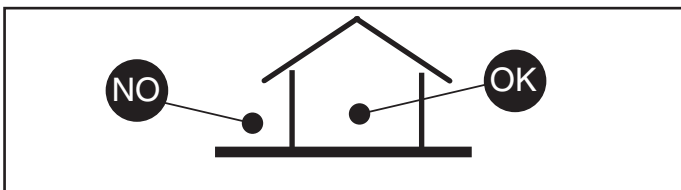

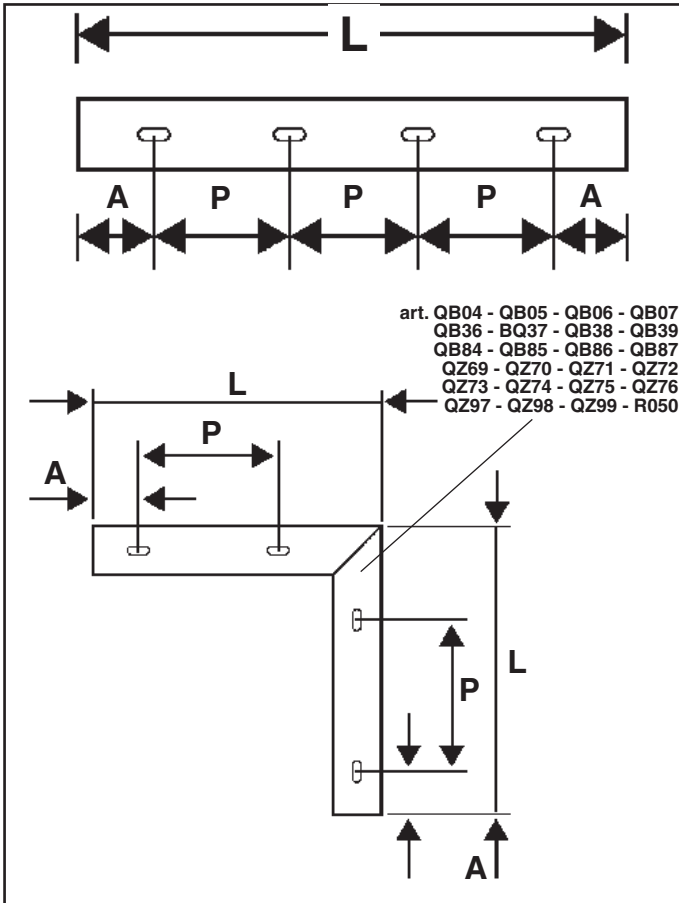

ART.	L (mm)	P (mm)	A (mm)
QA90 - QB70 - QZ57 - QZ85	612	250	140/222
QA91 - QB71 - QZ58 - QZ86	1208	500	354
QA92 - QB72 - QZ59 - QZ87	2397	800	398
QA93 - QB73 - QZ60 - QZ88	3596	1000	298
QA94 - QB74 - QZ61 - QZ89	898	500	199
QA95 - QB75 - QZ62 - QZ90	3596	1000	298
QB04 - QB05 - QB06 - QB07 QB36 - BQ37 - QB38 - QB39 QB84 - QB85 - QB86 - QB87 QZ69 - QZ70 - QZ71 - QZ72 QZ73 - QZ74 - QZ75 - QZ76 QZ97 - QZ98 - QZ99 - R050	642 x 642	250	180
QX48	1192	500	346
QX55	2384	800	392



IT Per le posizioni di installazione, attenersi a quelle illustrate, eventualmente contattare la iGuzzini.

EN All installation positions must comply with those illustrated. In the event of any doubt, contact iGuzzini.

FR Pour les positions d'installation, se conformer aux positions illustrées ; contacter la société iGuzzini en cas de nécessité

DE Für die Einbaupositionen die Abbildungen beachten. Eventuell iGuzzini kontaktieren.

NL Houd u voor de installatieposities aan degene die zijn weergegeven. Neem eventueel contact op met iGuzzini

ES Respetar las posiciones de instalación ilustradas y, en caso de duda, contactar con iGuzzini

DA For installationspositioner skal man holde sig til de viste, og eventuelt kontakte iGuzzini

NO For installasjonsplassingene henviser vi til illustrasjonene, eller ta eventuelt kontakt med iGuzzini

SV Följ de angivna positionerna för installationen. Kontakta vid behov iGuzzini

RU При выборе положения для монтажа следует обратиться к проиллюстрированным либо обратиться в компанию iGuzzini

ZH 安装位置请参考图示, 必要时也可联系iGuzzini

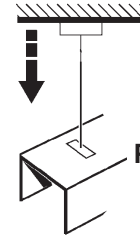

IN60 Led (MINIMAL) Pendant Mounted

IT Attenzione:

La sicurezza dell'apparecchio e' garantita solo con l'uso appropriato delle seguenti istruzioni; pertanto e' necessario conservarle.

EN Warning:

The safety of this fixture is guaranteed only if you comply with these instructions; remember to conserve in a safe place.

FR Attention:

La sécurité de l'appareil n'est garantie qu'en cas d'utilisation correcte des instructions suivantes; il faut par conséquent les conserver.

DE Achtung:

Die sicherheit des gerätes wird nur durch sachgemässe befolgung nachstehender anweisungen gewährleistet; ihre aufbewahrung ist deshalb sehr wichtig.

NL Opgelet:

De veiligheid van di atoestel is slechts dan gegarandeerd als indien de volgende instructies strikt worden toegepast: daarom moet men ze ook bewaren.

ES Atencion:

La seguridad del aparato se garantiza solo cumpliendo cuidadosamente las siguientes instrucciones; por ello, es necesario conservarlas.

DA Bemærk:

Sikkerheden ved brug af armaturet kan kun garanteres, hvis disse anvisninger følges; sørg derfor for at gemme dem.

NO Advarsel:

Sikkerheten til dette apparatet garanteres kun hvis du overholder disse instruksjonene; husk å oppbevare dem på et trygt sted.

SV Observera:

Utrustningens säkerhet kan endast garanteras om dessa anvisningar respekteras i detalj. Spara därför dessa anvisningar för framtida konsultation.

RU Внимание:

Мы гарантируем безопасную эксплуатацию изделия только при соблюдении следующих инструкций; с этой целью необходимо сохранить данную брошюру.

ZH 警告:

为确保该装置安全，请遵守操作指示；并于安全场所放置。

AR

تحذير : لا يمكن ضمان سلامة هذا الجهاز إلا إذا التزمت بهذه التعليمات. يجب حفظها في مكان آمن.

Installazione a sospensione
Suspension installation
Installation en suspension
Installation mit stahleilaufhängung
Het ophangen
Instalacion colgada
Pendelnde ophæng
Hengeinstallasjon
Hängande installation
ПОДВЕСНОЙ МОНТАЖ
吊顶式安装

تركيب بالتعليق

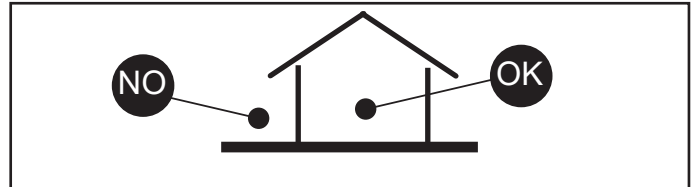

START

	General Lighting Version	UGR Version	MMO Version	Space Version
art. MWB4	✓	✓	✗	✗
MWB5 (DALI)	✓	✓	✓	✓
MWB2 (DALI Emergency)	✗	✗	✓	✓

	L START (mm)	P (mm)
2 x	612	512
	1208	1108
	2397	2297
	3596	3496
	1192	1092
	2384	2284

MIDDLE/END



	L MIDDLE (mm)	P (mm)
1 x	898	898
	1192	1192
	2384	2384
2 x	3596	1798

*



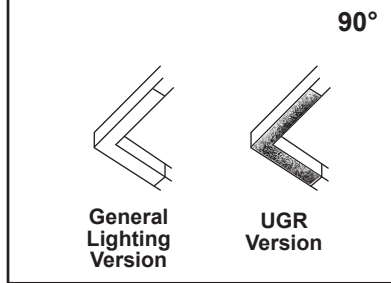

	L (mm)
2 x	642 x 642

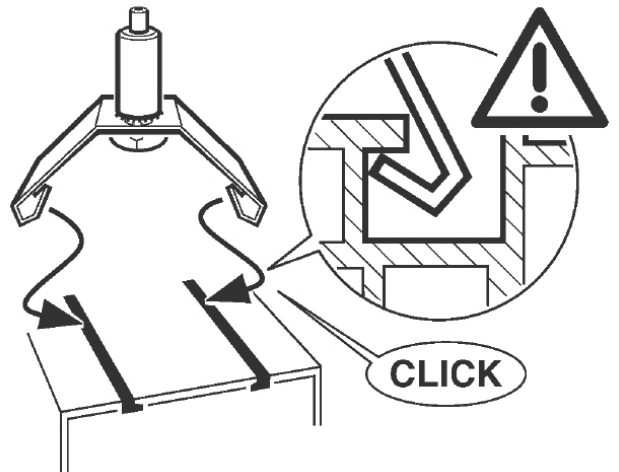
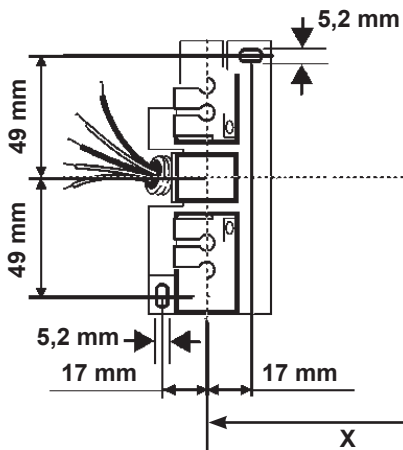
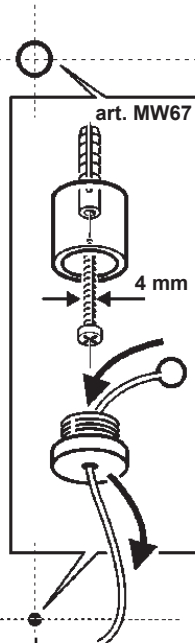
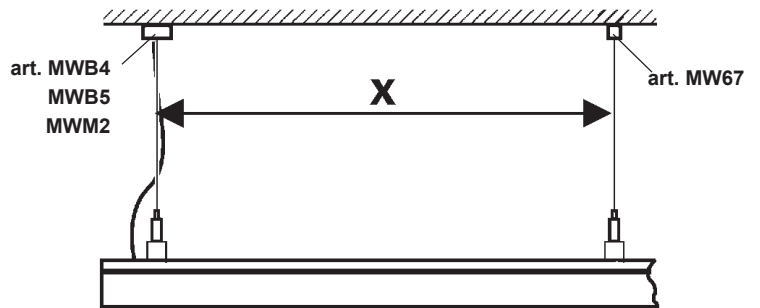

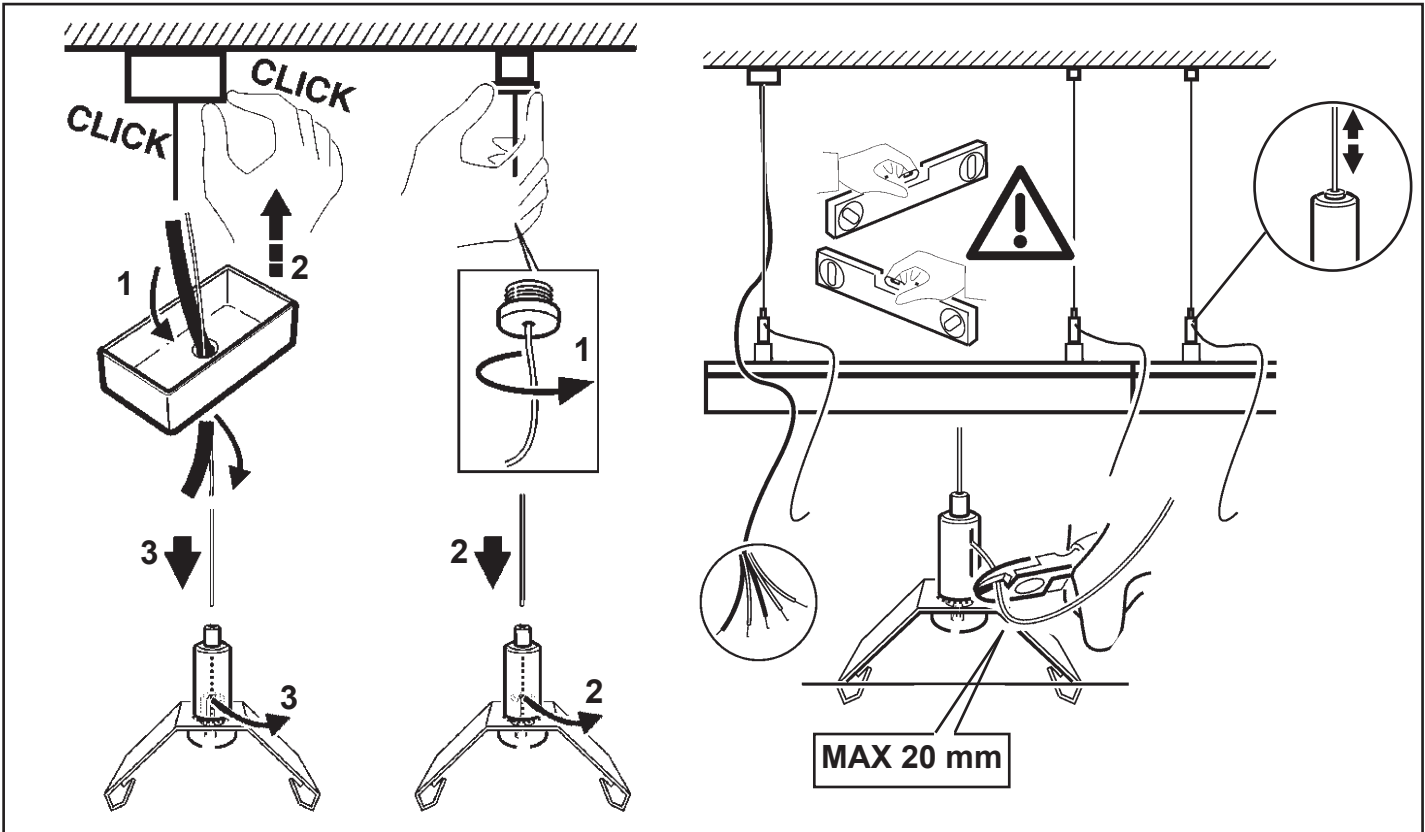
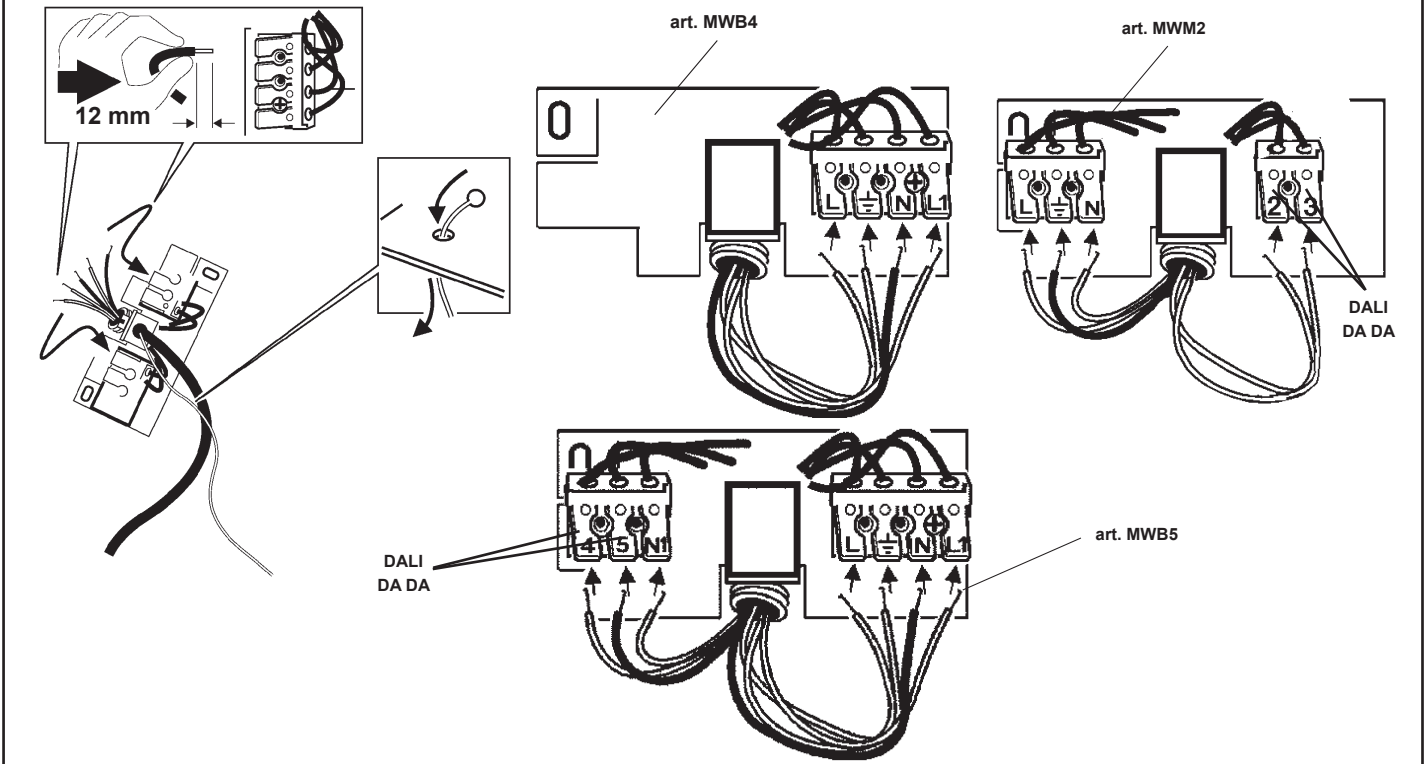

IT N.B.: Per la sostituzione del LED contattare l'azienda iGuzzini.
 EN N.B.: For information on LED replacement please contact iGuzzini.
 FR N.B.: Pour procéder au remplacement de la LED, adressez-vous à la société iGuzzini.
 DE N.B.: Bezüglich des Austausches der LED kontaktieren Sie bitte die Firma iGuzzini.
 NL N.B.: Voor het vervangen van de LED neemt u contact op met het bedrijf iGuzzini.
 ES NOTA: Para sustituir el LED llame a la empresa iGuzzini.
 DA N.B.: For udskiftning af lysdioden, skal man kontakte iGuzzini.
 NO N.B.: For informasjon om skifte av LED, vennligst ta kontakt med iGuzzini.
 SV OBS! För byte av lysdioden, kontakta företaget iGuzzini.
 RU ПРИМЕЧАНИЕ: Для замены СИДов обращайтесь в компанию iGuzzini.
 ZH 注意：如需LED更换的信息，请联系iGuzzini

AR تنبيه: لاستبدال الضوء LED اتصل بشركة iGuzzini



IN60
MMO version
Space version

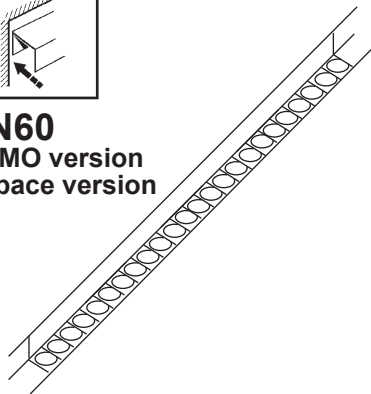

IT ATTENZIONE:

LA SICUREZZA DELL'APPARECCHIO E' GARANTITA SOLO CON L'USO APPROPRIATO DELLE SEGUENTI ISTRUZIONI; PERTANTO E' NECESSARIO CONSERVARLE.

EN WARNING:

THE SAFETY OF THIS FIXTURE IS GUARANTEED ONLY IF YOU COMPLY WITH THESE INSTRUCTIONS; REMEMBER TO CONSERVE IN A SAFE PLACE.

FR ATTENTION:

LA SECURITE DE L'APPAREIL N'EST GARANTIE QU'EN CAS D'UTILISATION CORRECTE DES INSTRUCTIONS SUIVANTES; IL FAUT PAR CONSEQUENT LES CONSERVER.

DE ACHTUNG:

DIE SICHERHEIT DES GERÄTES WIRD NUR DURCH SACHGEMÄSSE BEFOLGUNG NACHSTEHENDER ANWEISUNGEN GEWÄHRLEISTET; IHRE AUFBEWAHRUNG IST DESHALB SEHR WICHTIG.

NL OPGELET:

DE VEILIGHEID VAN DI ATOESTEL IS SLECHTS DAN GEGARANDEERD ALS INDIEN DE VOLGENDE INSTRUCITIES STRIKT WORDEN TOEGEPAST: DAAROM MOET MEN ZE OOK BEWAREN.

ES ATENCION:

LA SEGURIDAD DEL APARATO SE GARANTIZA SOLO CUMPLIENDO CUIDADOSAMENTE LAS SIGUIENTES INSTRUCCIONES; POR ELLO, ES NECESARIO CONSERVARLAS.

DA BEMÆRK:

SIKKERHEDEN VED BRUG AF ARMATURET KAN KUN GARANTERES, HVIS DISSE ANVISNINGER FØLGES; SØRG DERFOR FOR AT GEMME DEM.

NO ADVARSEL:

SIKKERHETEN TIL DETTE APPARATET GARANTERES KUN HVIS DU OVERHOLDER DISSE INSTRUKSJONENE; HUSK Å OPPBEVARE DEM PÅ ET TRYGT STED.

SV OBSERVERA!

UTRUSTNINGENS SÄKERHET KAN ENDAST GARANTERAS OM DESSA ANVISNINGAR RESPEKTERAS I DETALJ. SPARA DÄRFÖR DESSA ANVISNINGAR FÖR FRAMTIDA KONSULTATION.

RU ВНИМАНИЕ:

МЫ ГАРАНТИРУЕМ БЕЗОПАСНУЮ ЭКСПЛУАТАЦИЮ ИЗДЕЛИЯ ТОЛЬКО ПРИ СОБЛЮЖЕНИИ СЛЕДУЮЩИХ ИНСТРУКЦИЙ; С ЭТОЙ ЦЕЛЬЮ НЕОБХОДИМО СОХРАНИТЬ ДАННУЮ БРОШЮРУ.

ZH 警告

为确保该装置安全，请遵守操作指示；并于安全场所放置。



IT N.B.: DURANTE L'INSTALLAZIONE DEL SISTEMA "IN 60 LED" RISPETTARE SCRUPOLOSAMENTE LE NORME IMPIANTISTICHE NAZIONALI VIGENTI.

EN N.B.: WHEN INSTALLING THE "IN 60 LED" SYSTEM, MAKE SURE ALL CURRENT NATIONAL REGULATIONS RELATING TO INSTALLATION ARE OBSERVED.

FR N.B.: LORS DE L'INSTALLATION DU SYSTÈME "IN 60 LED" VEUILLEZ RESPECTER RIGOREUSEMENT LES NORMES EN VIGUEUR EN LA MATIÈRE DANS LE PAYS.

DE N.B.: BEACHTEN SIE BEI DER INSTALLATION DES SYSTEMS "IN 60 LED" UNBEDINGT DIE IM LAND GELTENDEN ANLAGETECHNISCHEN VORSCHRIFTEN.

NL N.B.: BIJ HET INSTALLEREN VAN HET "IN 60 LED" SYSTEEM MOET U DE GELDENDE NATIONALE INSTALLATIENORMEN STRIKT NALEVEN.

ES NOTA: DURANTE LA INSTALACIÓN DEL SISTEMA "IN 60 LED" RESPETAR ESCRUPULOSAMENTE LAS NORMAS NACIONALES DE INSTALACIÓN EN VIGOR.

DA N.B.: UNDER INSTALLATION AF "IN 60 LED" SYSTEMET SKAL MAN NØJE OVERHOLDE DE GÆLDENDE REGLER FOR DISSE ANLÆG.

NO N.B.: UNDER INSTALLASJON AV SYSTEMET "IN 60 LED" MÅ DE NASJONALE ANLEGGSFORSKRIFTENE OVERHOLDES NØYE.

SV OBS! UNDER INSTALLATIONEN AV SYSTEMET "IN 60 LED" SKAGÄLLANDE NATIONELLA INSTALLATIONSFÖRESKRIFTER RESPEKTERAS I DETALJ.

RU ПРИМЕЧАНИЕ: В ПРОЦЕССЕ МОНТАЖА СИСТЕМЫ "IN 60 LED" СТРОГО СОБЛЮДАЙТЕ НАЦИОНАЛЬНЫЕ ДЕЙСТВУЮЩИЕ НОРМАТИВЫ ПО ЭЛЕКТРОПРОВОДКЕ.

ZH 重要：安装 "IN 60 LED" 系统时请始终参照标准系统

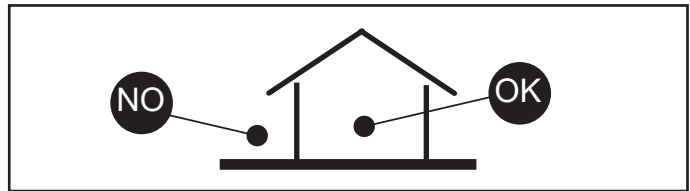

IT INSTALLAZIONE SUL CONTROSOFFITTO
EN INSTALLATION ON CEILING
FR INSTALLATION AU FAUX-PLAFOND
DE INSTALLATION AN DER HÄNGEDECKE
NL HET INSTALLEREN IN HET VERLAAGDE PLAFOND
ES INSTALACION SOBRE FALSO TECHO
DA INSTALLATION PÅ FORSÆNKET LOFT
NO MONTERING I TAKET
SV INSTALLATION I UNDERTAK
RU МОНТАЖ В ФАЛЬШ-ПОТОЛКЕ
ZH 吸顶式安装天花板上的安装

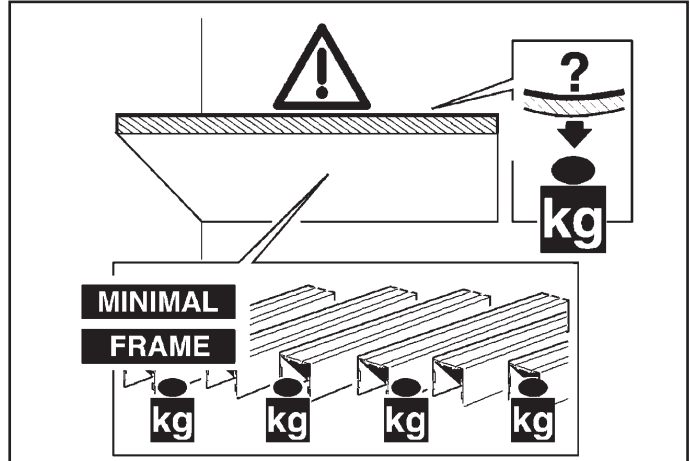

IT N.B.: E' responsabilità dell'utente verificare la resistenza del controsoffitto, in funzione del peso degli apparecchi installati.
EN N.B.: It is the user's responsibility to check the strength of the false ceiling with respect to the weight of the fixtures installed.
FR N.B.: Il appartient à l'utilisateur de vérifier la résistance du faux plafond en fonction du poids des appareils installés.
DE N.B.: Es obliegt dem Verbraucher sicherzustellen, daß die Deckenverkleidung das Gewicht der Einbauleuchte aufnehmen kann.
NL N.B.: Het is de verantwoordelijkheid van de koper zich ervan te verzekeren dat het verlaagde plafond stevig genoeg is voor het dragen van het gewicht van de geïnstalleerde apparaten.
ES NOTA: Corresponde al usuario efectuar las pruebas en el falso techo, en función del peso de los aparatos instalados.
DA N.B.: Det er brugerens ansvar, at kontrollere loftets modstanddygtighed, ud fra de installerede apparaters vægt.
NO N.B.: Det er brukerens ansvar å kontrollere himlingens/takets motstandskraft, på grunnlag av de installerte apparatens vekt.
SV OBS! Det är användarens ansvar att kontrollera takets hållfasthet i förhållande till vikten på installerad utrustning.
RU ПРИМЕЧАНИЕ: Пользователь должен проверить прочность фальш-потолка в соответствии с весом устанавливаемых в него приборов.
ZH 注意：用户须根据安装装置的重量 检查天花板的强度。

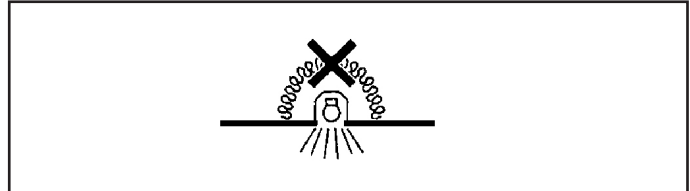

IT N.B.: Apparecchi non idonei ad essere coperti di materiale termicamente isolante
EN N.B.: Fixtures not suitable to be covered in thermally-insulating material.
FR N.B.: Appareils ne pouvant pas être couverts de matériau d'isolation thermique
DE N.B.: Geräte nicht geeignet, um mit wärmeisolierendem Material abgedeckt zu werden
NL N.B.: Deze apparaten zijn niet geschikt om te worden bedekt met thermisch isolerend materiaal
ES NOTA: Aparatos no aptos para ser cubiertos de material térmicamente aislante
DA N.B.: Armaturerne må ikke dækkes af varmeisolerende materiale.
NO N.B.: Apparaten passer ikke til å dækkes av termoisolerende materialer.
SV OBS! Utrustningen får inte täckas över med värmeisolerande material
RU Внимание: Приборы непригодны для покрытия термоизоляционным материалом.
ZH 灯具不适用隔热材料加以覆盖。

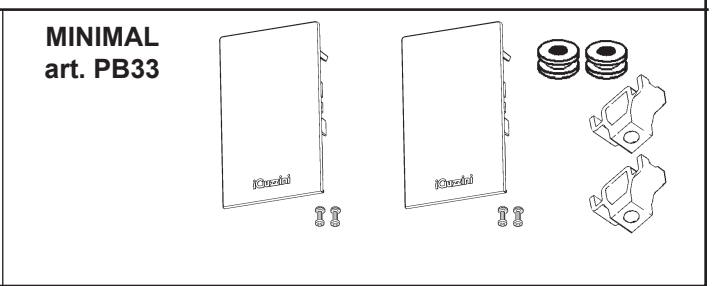
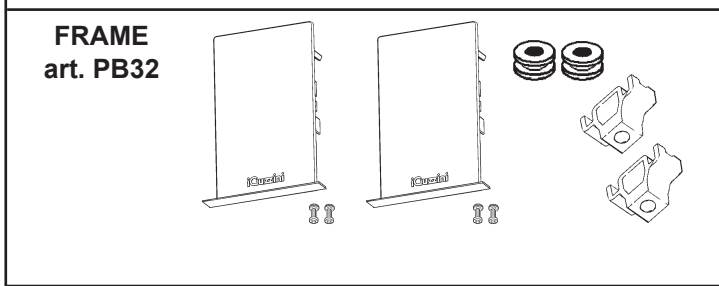
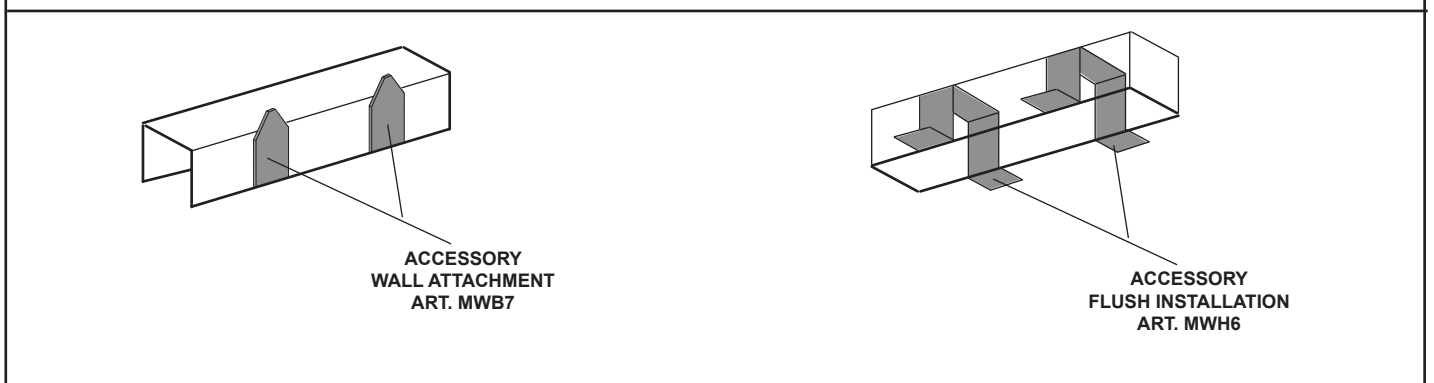
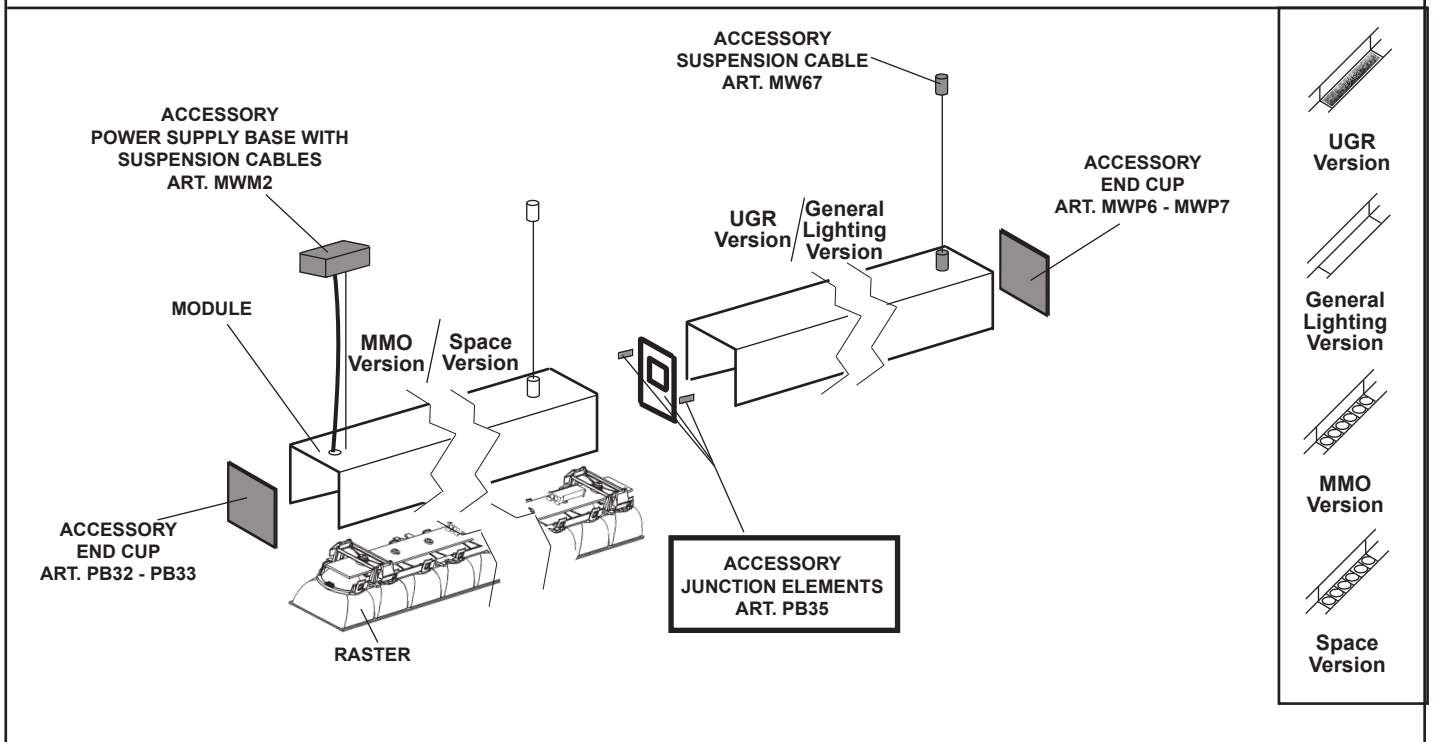
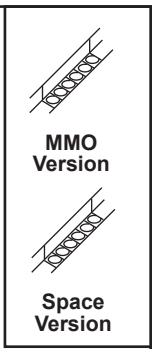

DOWN

L (mm)	MODULE 	RASTER 
1192	QX47 - QX48	QX89 - QX90 - QX91 - QX92 - QX93 - QX94 - QX95 - QX96 - QX97 - QX98 - QX99 - QY00 - QY01 - QY02 - QY03 - QY04 R526 - R527 - R528 - R529 - R530 - R531 - R532 - R533 - R534 - R535 - R536 - R537 - R538 - R539 - R540 - R541
2384	QX54 - QX55	QY18 - QY19 - QY20 - QY21 - QY22 - QY23 - QY24 - QY25 R555 - R556 - R557 - R558 - R559 - R560 - R561 - R562

UP/ DOWN

L (mm)	MODULE 	RASTER 
1192	QX49 - QX50 - QX51 - QX52 QX53	QY05 - QY06 - QY07 - QY08 - QY09 - QY10 - QY11 - QY12 - QY14 - QY15 - QY16 - QY17 R542 - R543 - R544 - R545 - R546 - R547 - R548 - R549 - R551 - R552 - R553 - R554 QY13 - R550
2384	QX56 - QX57 - QX58 - QX59	QY26 - QY27 - QY28 - QY29 - QY30 - QY31 - QY32 - QY33 - QY34 - QY35 - QY36 - QY37 R563 - R564 - R565 - R566 - R567 - R568 - R569 - R570 - R571 - R572 - R573 - R574

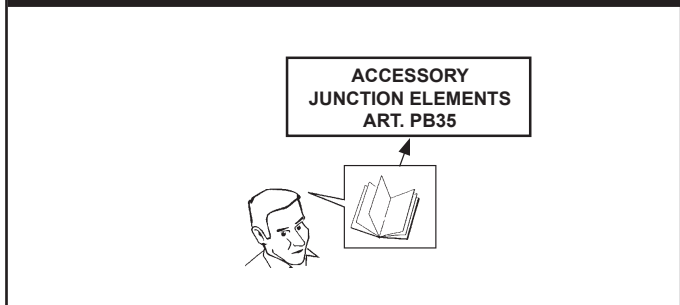
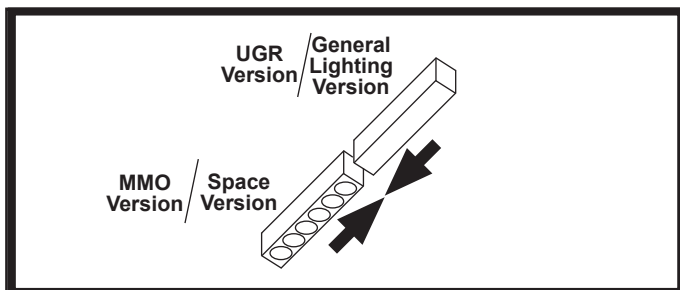



art. PB34

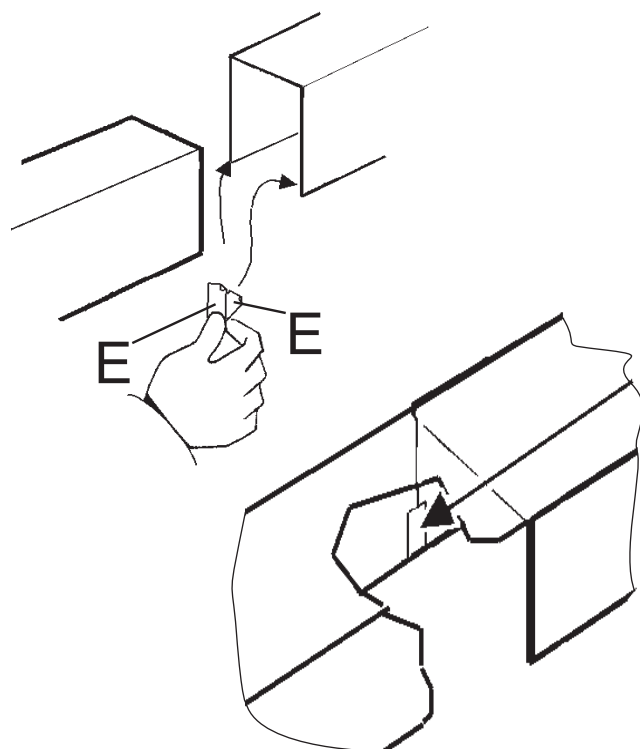
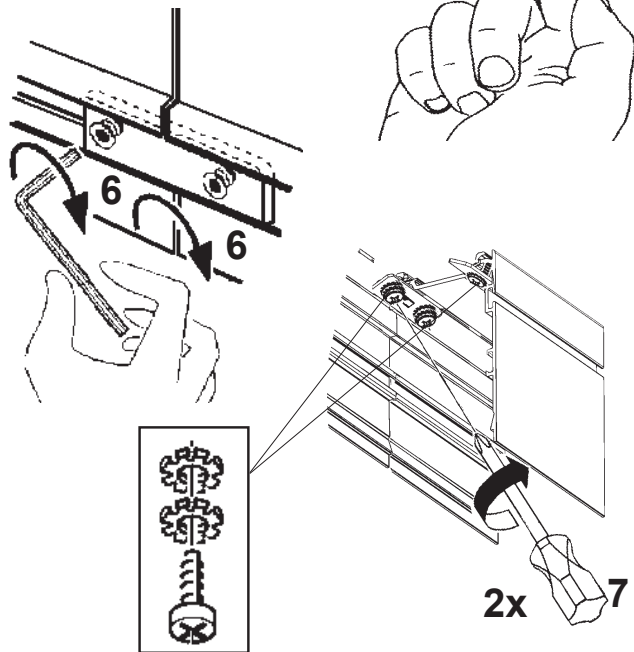
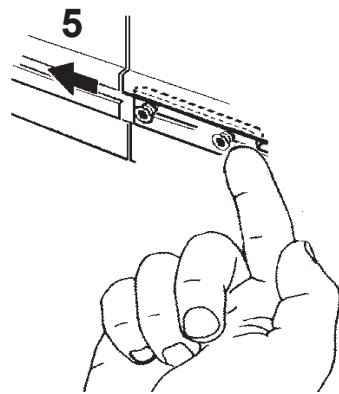
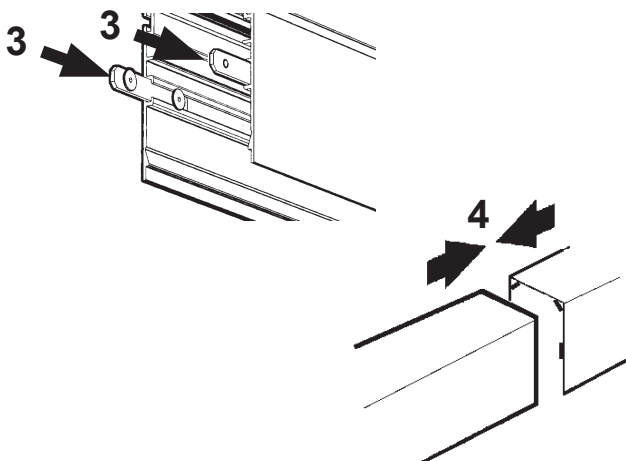
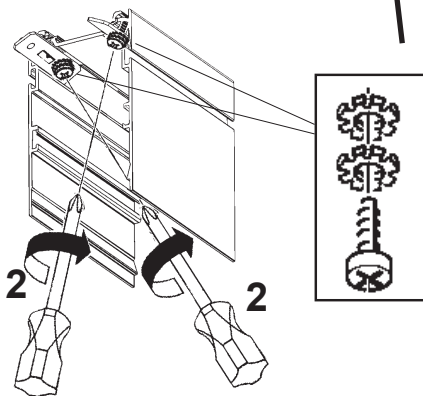
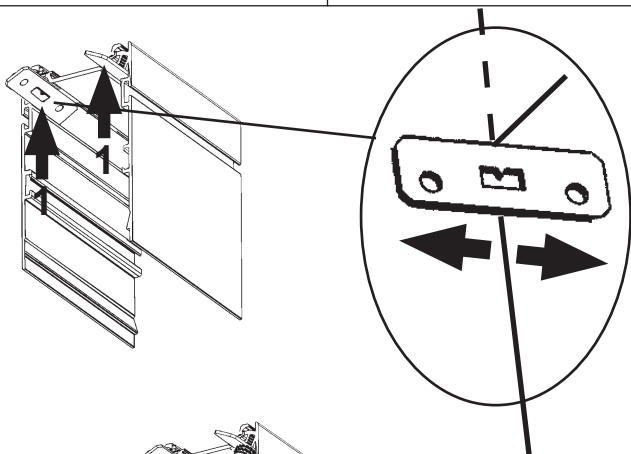
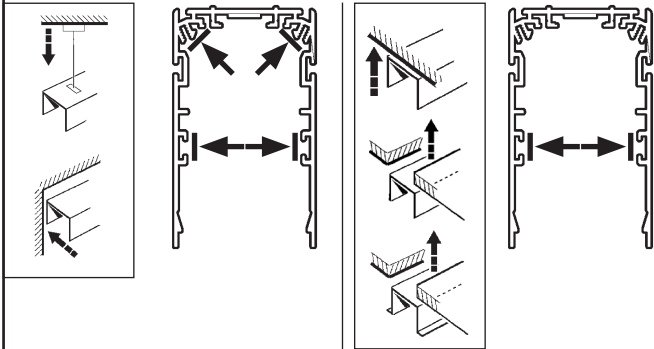

- IT Applicare l'etichetta "E" come mostrato in figura.
- EN Apply label "E" as shown in the figure.
- FR Appliquez l'étiquette "E" comme illustré (voir figure).
- DE Bringen Sie das Etikett "E" wie in der Abbildung dargestellt an.
- NL Bevestig het etiket "E" zoals aangegeven in de figuur.
- ES Aplicar la etiqueta "E" según ilustrado en la figura.
- DA Sæt mærkatet "E" på, som vist i figuren.
- NO Innrett merke "E" slik som vist på figuren.
- SV Applicera etiketten "E" enligt figuren.
- RU Нанесите этикетку «E», как показано на схеме.
- ZH 按表中所示贴上标签"E"。

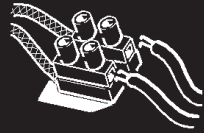

IT DETERMINAZIONE DELLE CORRENTI MASSIME AMMISSIBILI
EN DETERMINING THE MAXIMUM PERMITTED CURRENT
FR DETERMINATION DES COURANTS MAXIMAUX ADMISSIBLES
DE BESTIMMUNG DER ZULÄSSIGEN HÖCHSTSTRÖME
NL VASTSTELLEN VAN DE MAXIMAAAL TOEGESTANE STROOMTOEVOER
ES DETERMINACIÓN DE LAS CORRIENTES MÁXIMAS PERMITIDAS
DA BESTEMMELSE AF MAKS. TILLADT STRØMSTYRKE
NO BESTEMME MAKSIMAL TILLATT STRØM
SV FASTSTÄLLANDE MAX. TILLÅTEN STRÖM
RU ОПРЕДЕЛЕНИЕ МАКСИМАЛЬНОГО ДОПУСТИМОГО ТОКА
ZH 确定最大通过电流

IT Nella progettazione dell'impianto illuminotecnico ed elettrico, determinare le correnti massime ammissibili, considerando i seguenti fattori:
 - 9A corrente nominale ammessa dai morsetti
 - coefficiente di sicurezza per tenere conto delle sovratensioni e contemporaneità;
 - corrente nominale assorbita dai singoli moduli (vedi tabella)

EN When planning the lighting and electrical system, determine the maximum permitted current taking into account the following factors:
 - 9A the nominal current permitted by terminal block
 - safety coefficient to allow for excess voltage and contemporaneity
 - the nominal current absorbed by single modules (see table)

FR Lors de l'étude de projet de l'installation d'éclairage et de l'installation électrique, déterminer les courants maximaux admissibles en tenant compte des facteurs suivants :
 - 9A courant maximal admis par le bornier
 - coefficient de sécurité tenant compte des surtensions et de la simultanéité;
 - courant nominal absorbé par les différents modules (voir tableau)

DE Bei der Planung einer Beleuchtungs- und Elektroanlage bestimmen Sie die zulässigen Höchstströme unter Berücksichtigung folgender Faktoren:
 - 9A von den Klemmleiste zugelassener Nennstrom
 - Sicherheitskoeffizient zur Einbeziehung von Überspannung und Gleichzeitigkeit;
 - von den einzelnen Modulen aufgenommener Nennstrom (siehe Tabelle)

NL Bij het ontwerpen van de verlichtingstechnische en elektrische installatie moet u de maximaal toegestane stroomtoevoer vaststellen door rekening te houden met de volgende factoren:
 - 9A nominale stroom toegestaan op klemmenstroken
 - veiligheidscoëfficiënt om rekening te houden met overspanning en gelijktijdigheid;
 - nominale opgenomen stroom van de enkele modules (zie tabel)

ES Durante la proyección de la instalación luminotécnica y eléctrica, determinar las corrientes máximas permitidas, en consideración de los factores siguientes:
 - 9A corriente nominal permitida de la bornera
 - coeficiente de seguridad para considerar sobretensiones y contemporaneidades
 - corriente nominal absorbida por los módulos individuales (ver tabla)

DA I projekteringen af det belysnings-tekniske og elektriske anlæg, skal man undersøge den maks. tilladte strømstyrke, idet man tager højde for følgende:
 - 9A den nominelle, tilladte strømstyrke fra klæmkerne
 - sikkerhedsfaktor for at sikre mod overspænding og samtidighedsfaktor
 - absorberet nominal strømstyrke på de enkelte moduler (se tabellen).

NO Ved planlegging av lys- og elektrisk system, bestem maksimalt tillatt strøm, ta med betraktningen følgende faktorer:
 - 9A nominell strøm tillatt av terminalblokkene
 - sikkerhetskoeffisiens for å tillate overflødig spenning og aktualitet,
 - nominell strøm absorbert av enkeltmoduler (se tabel)

SV Vid projekteringen av belysnings-systemet och det elektriska systemet ska max. tillåten ström fastställas. Ta hänsyn till följande faktorer:
 - 9A Tillåten nominell ström från kopplingsplintarna
 - Säkerhetskoefficient för att ta hänsyn till överspänningar och sammanlagringar
 - Tillförd nominell ström från enskilda moduler (se tabell).

RU При расчёте светотехнической системы и электропроводки определите максимальный допустимый ток с учетом следующих факторов:
 - 9A номинальный допустимый ток на клеммных колодках
 - коэффициент безопасности для учета перенапряжения и одновременного включения различных приборов;
 - номинальный ток, поглощаемый отдельными модулями (см. таблицу)

ZH 规划照明和电路系统时，确定最大允许电流，并考虑下列因素：
 - 9A 接线排 允许的正常电流
 - 允许超过规定电压和同时性的安全系数；
 - 为单个模块使用的常规电流（见表）

I Tra i conduttori di alimentazione e quelli di controllo è garantito un isolamento fondamentale.

EN Insulation is guaranteed between the power supply wires and the control wires basic.

FR Entre les conducteurs d'alimentation et les conducteurs de commande, une isolation est garantie fondamentale.

DE Zwischen den Versorgungs- und Steuerungsleitern ist eine Isolierung Basis gewährleistet.

NL Tussen de geleiders van de voeding en de controle wordt een isolatie gewaarborgd fundamenteel.

ES Entre los conductores de alimentación y los de control está garantizado el aislamiento fundamental.

DA Der er garanteret en isolering grundlæggende imellem forsyningslederne og styrelederne.

NO Det garanteres en isolering fundamental mellom strømlederne og kontrolllederne.

SV Det garanteras isolering grundläggande mellan matningsledare och kontrollkablar.

RU Гарантируется развязка цепей питания и управления фундаментальная.

ZH 电源线和控制线之间有绝缘保证基本。

ART.	CARICO DALI / DALI LOAD CHARGE DALI (COURANT MAXI ADMISSIBLE) DALI-LAST DALI VERMOGEN CARGA DALI DALI STRØMSTYRKE BELASTNING FOR "DALI" DALI-BELASTNING МАКС. ТОК СИСТЕМЫ DALI С РЕГУЛЯЦИЕЙ ИНТЕНСИВНОСТИ СВЕТА DALI 智能调光系统允许的最大电流量	INDIRIZZI DALI DALI ADDRESSES ADRESSES DALI DALI-ADRESSEN DALI ADRESSEN DIRECCIONES DALI DALI ADDRESSER ADRESSER TIL "DALI" DALI-ADRESSER ЛОГИЧЕСКИЕ АДРЕСА СИСТЕМЫ DALI DALI 智能调光系统计算机指 定控制参数	PROTOCOLLO DALI DEVICE TYPE
QX89 - QX90 - QX91 - QX92 - QX93 - QX94 QX95 - QX96 - QY05 - QY06 - QY07 - QY08 QY09 - QY10 - QY11 - QY12 - QY18 - QY19 QY20 - QY21 - QY22 - QY23 - QY24 - QY25 QY26 - QY28 - QY30 - QY32 - R526 - R527 R528 - R529 - R530 - R531 - R532 - R533 R542 - R543 - R544 - R545 - R546 - R547 R548 - R549 - R555 - R556 - R557 - R558 R559 - R560 - R561 - R562 - R563 - R565 R567 - R569	1 (2 mA)	1	DT6
QY14 - QY15 - QY16 - QY17 QY34 - QY35 - QY36 - QY37 R551 - R552 - R553 - R554 R571 - R572 - R573 - R574		2	DT6
QY13 - R550		1	DT8
QY27 - QY29 - QY31 - QY33 R564 - R566 - R568 - R570	2 (4 mA)	2	DT6

MINIMAL DOWN

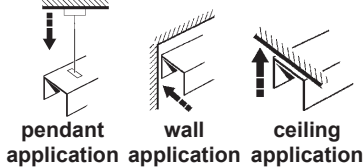

FRAME MINIMAL

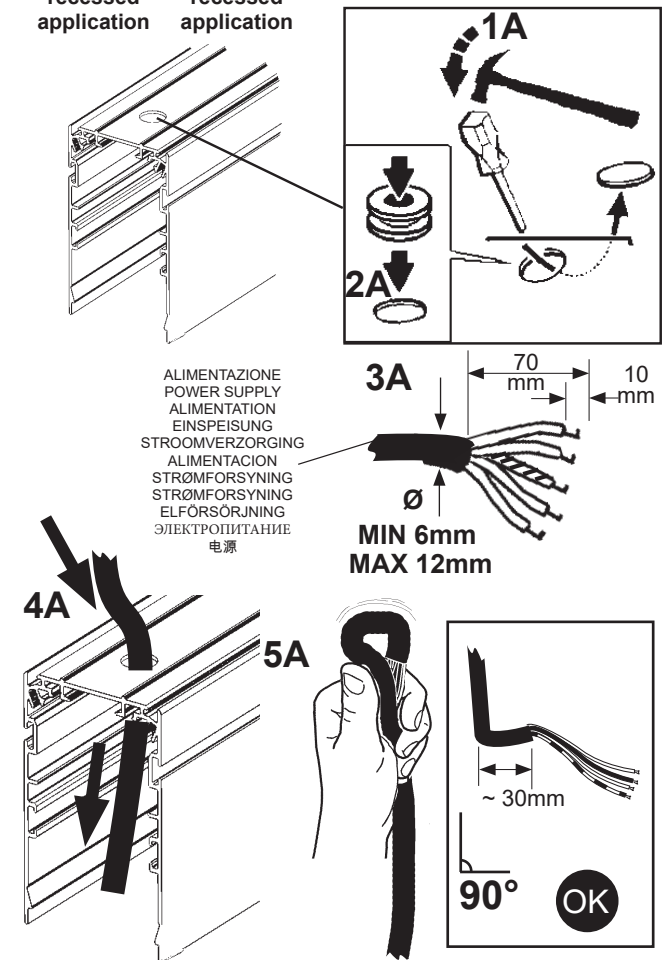
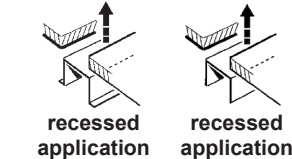

MINIMAL UP/DOWN

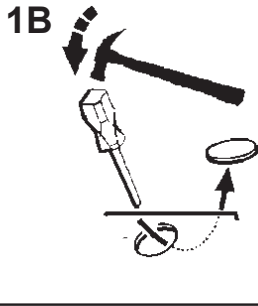
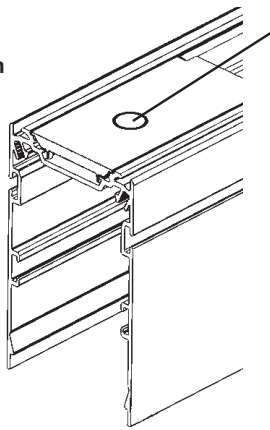
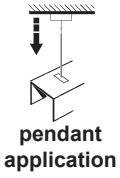

ALIMENTAZIONE
POWER SUPPLY
ALIMENTATION
EINSPEISUNG
STROOMVERZORGING
ALIMENTACION
STRØMFORSYNING
STRØMFORSYNING
ELFORSØRNING
ЭЛЕКТРОПИТАНИЕ
电源

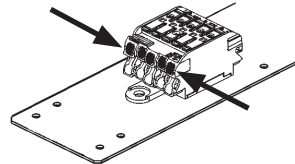
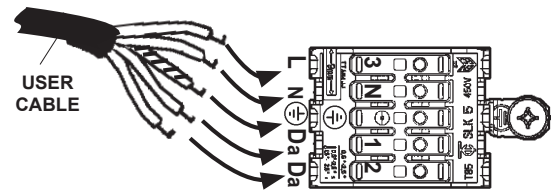
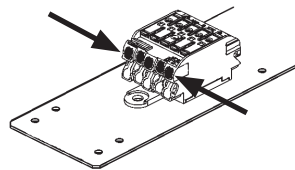
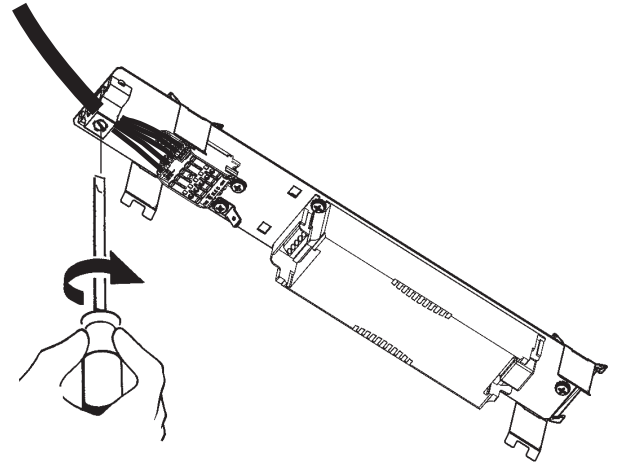
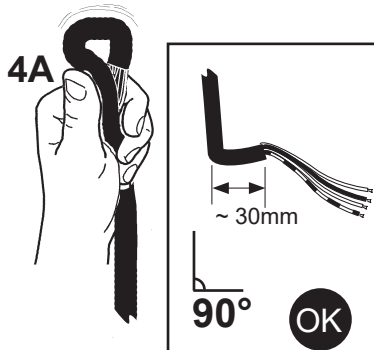
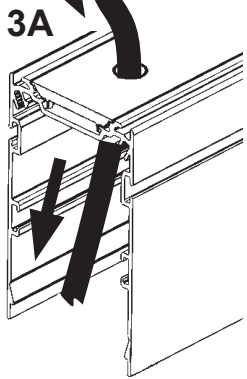
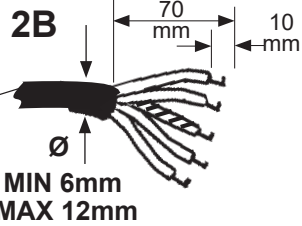

art. MWM2



art. PB32 - PB33

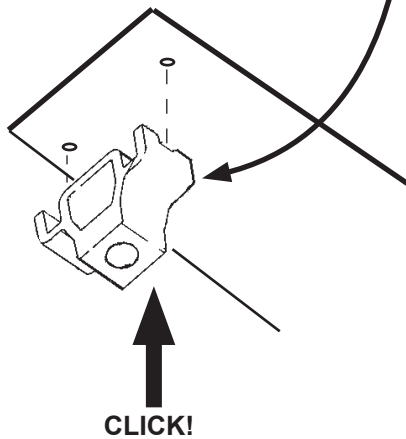
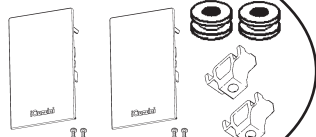

ROSSO
RED
ROUGE
ROT
ROOD
ROJO
RØD
RÖD
RÖD
КРАСНЫЙ
红色

BIANCO
WHITE
BLANC
WEISS
WIT
BLANCO
HVID
HVID
ВІТ
БЕЛЫЙ
白色的

ART.
MWM2
CABLE

GIALLO-VERDE
YELLOW-GREEN
JAUNE - VERT
GELB-GRÜN
GELBGRÖEN
AMARILLO-VERDE
GUL-GRÖNN
GUL-GRÖN
GULGRÖN
ЖЕЛТО-ЗЕЛЕНый
-ПРОВОД
綠線黃線

BLU
BLUE
BLEU
BLAU
BLAUW
AZUL
BLA
BLA
BLA
СИНИЙ
蓝色

MARRONE
BROWN
MARRON
BRAUN
BRUIN
MARRÓN
BRUN
BRUN
BRUN
КОРИЧНЕВый
棕色

Da Da N L

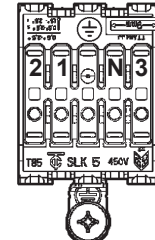

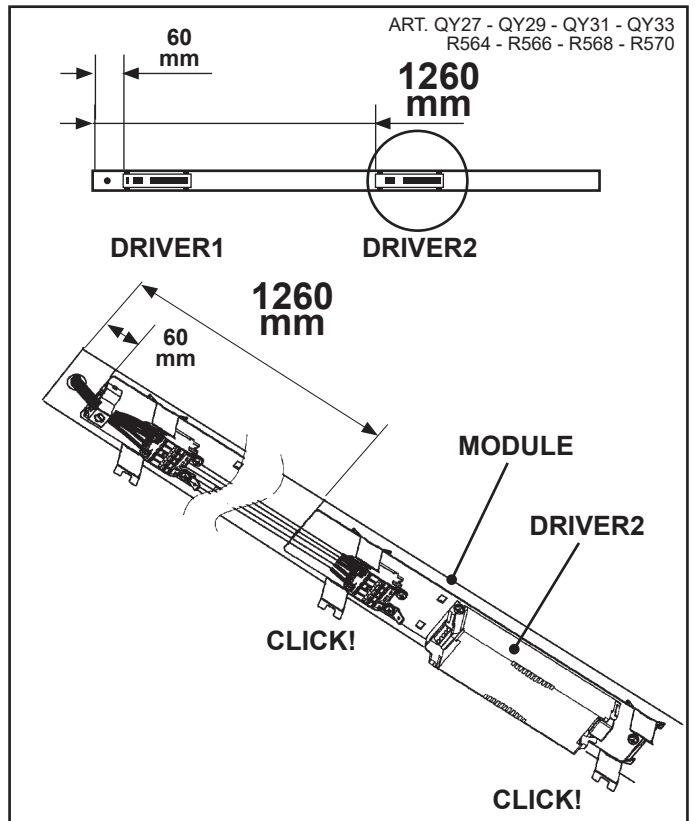
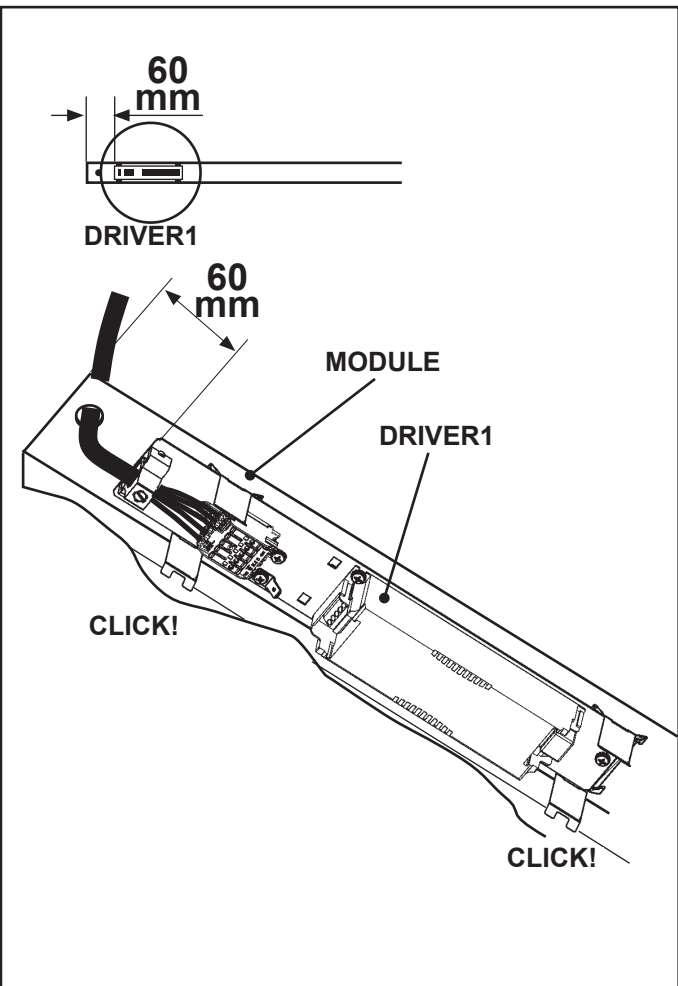
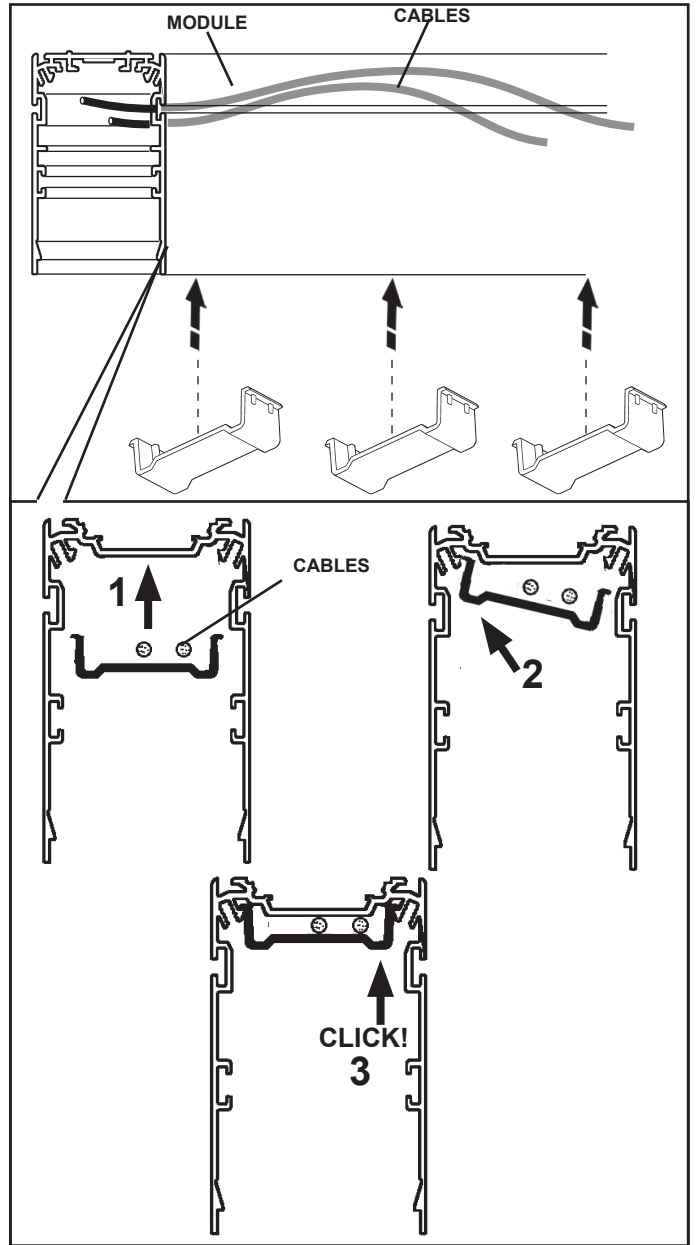
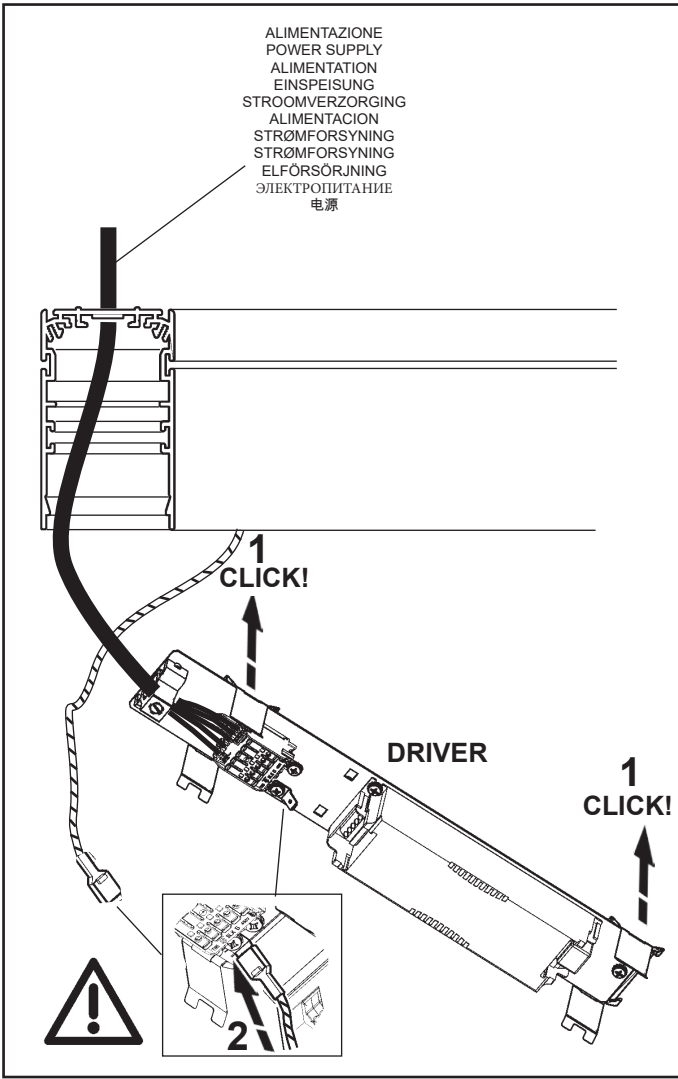

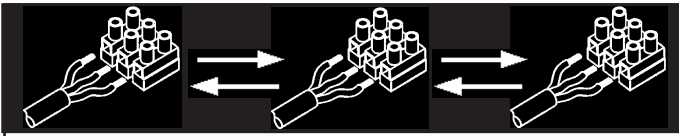

art. PB34 - PB35
CABLES
2,4m

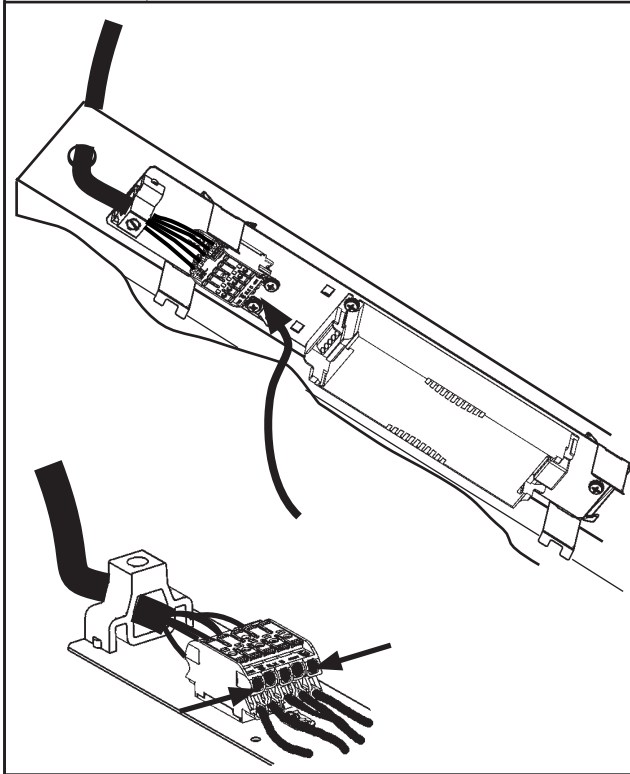

art. QY27 - QY29 - QY31 - QY33
R564 - R566 - R568 - R570

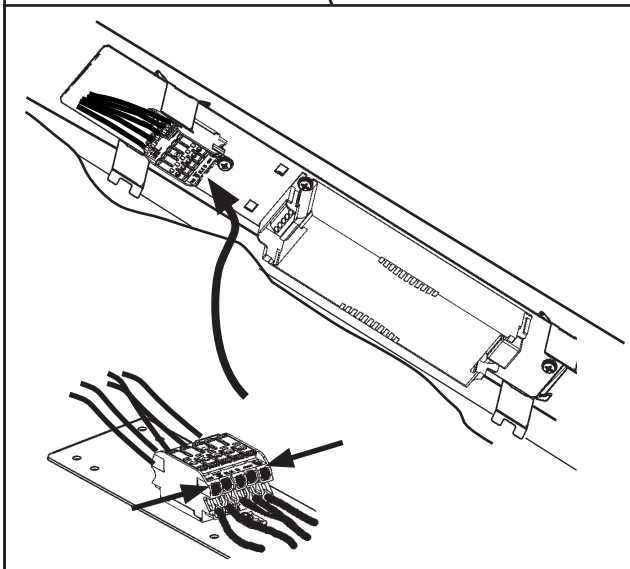

Da Da ⊕ N L

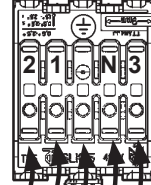

BIANCO
WHITE
BLANC
WEISS
WIT
BLANCO
HVID
HVID
ВИТ
БЕЛЫЙ
白色的

MARRONE
BROWN
MARRON
BRAUN
BRUN
MARRÓN
BRUN
BRUN
BRUN
КОРИЧНЕВЫЙ
棕色

art. PB34 - PB35
CABLES
2,4m

GIALLO-VERDE
YELLOW-GREEN
JAUNE - VERT
GELB-GRÜN
GELB-GRÜN
AMARILLO-VERDE
GUL-GRÖNN
GUL-GRÖN
GULGRÖN
ЖЕЛТО-ЗЕЛЕНый
ПРОВОД
绿线黄线

BLU
BLUE
BLEU
BLAU
BLAUW
AZUL
BLA
BLA
BLA
СИНИЙ
蓝色

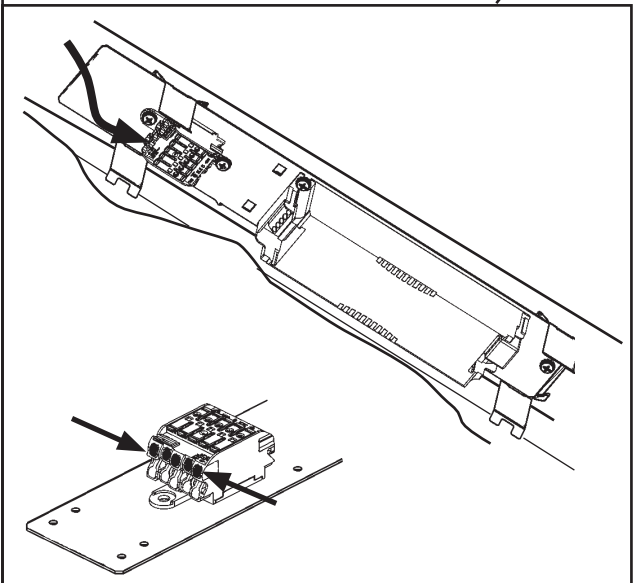
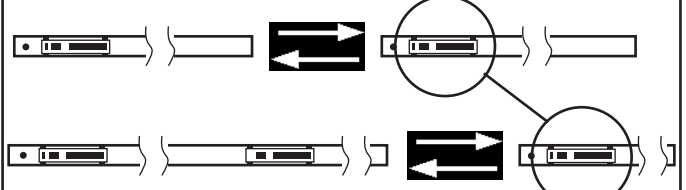

BIANCO
WHITE
BLANC
WEISS
WIT
BLANCO
HVID
HVID
ВИТ
БЕЛЫЙ
白色的

GIALLO-VERDE
YELLOW-GREEN
JAUNE - VERT
GELB-GRÜN
GELB-GRÜN
AMARILLO-VERDE
GUL-GRÖNN
GUL-GRÖN
GULGRÖN
ЖЕЛТО-ЗЕЛЕНый
ПРОВОД
绿线黄线

MARRONE
BROWN
MARRON
BRAUN
BRUN
MARRÓN
BRUN
BRUN
BRUN
КОРИЧНЕВЫЙ
棕色

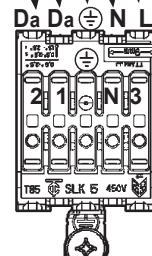

BLU
BLUE
BLEU
BLAU
BLAUW
AZUL
BLA
BLA
BLA
СИНИЙ
蓝色

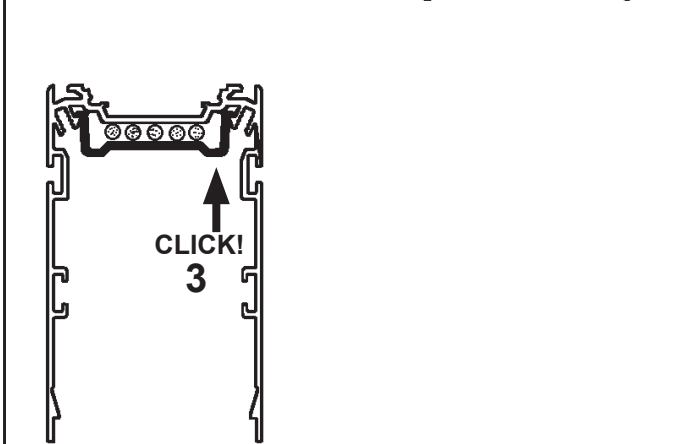
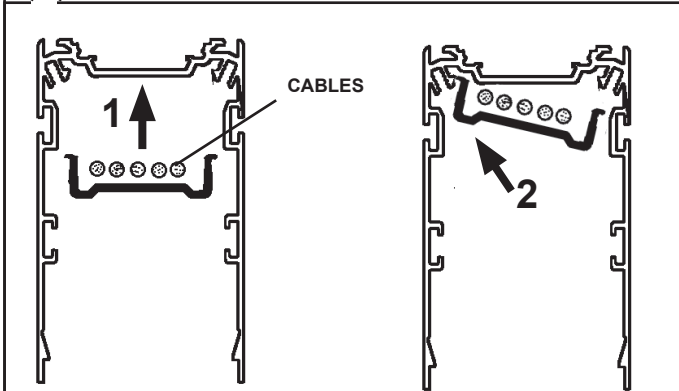
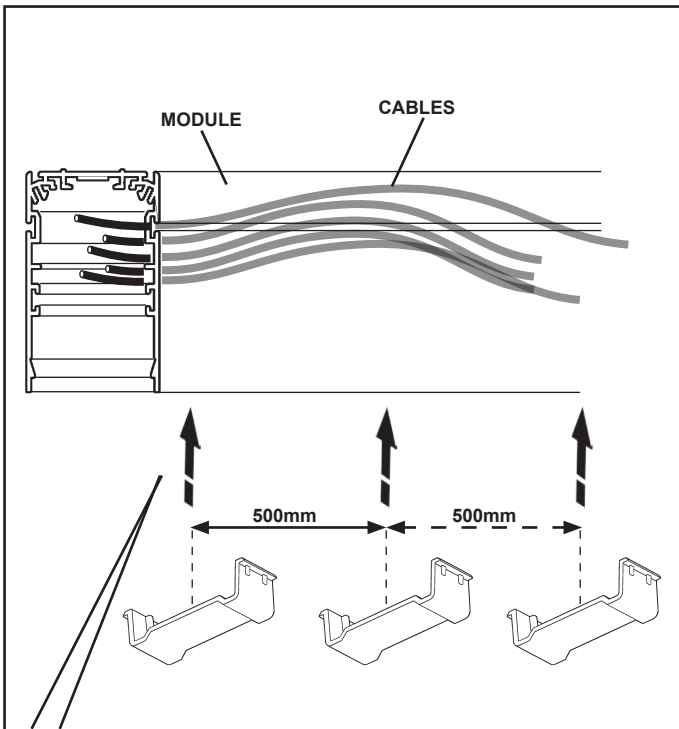

UP/DOWN version

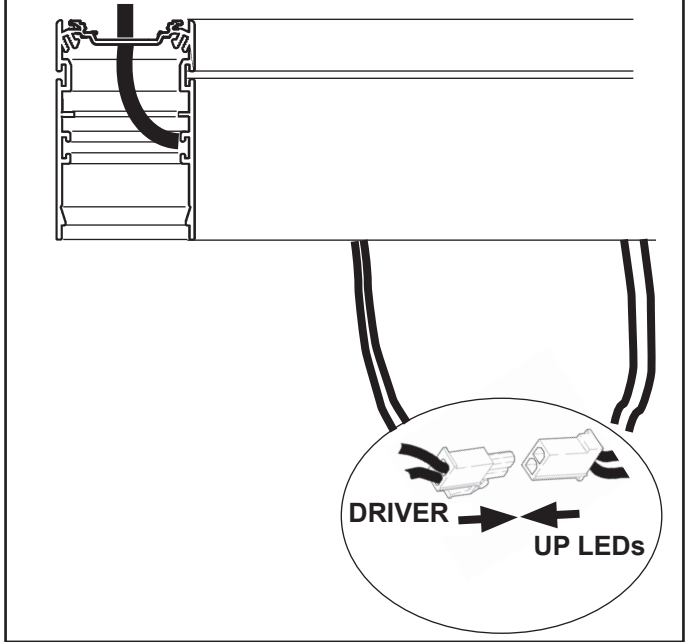



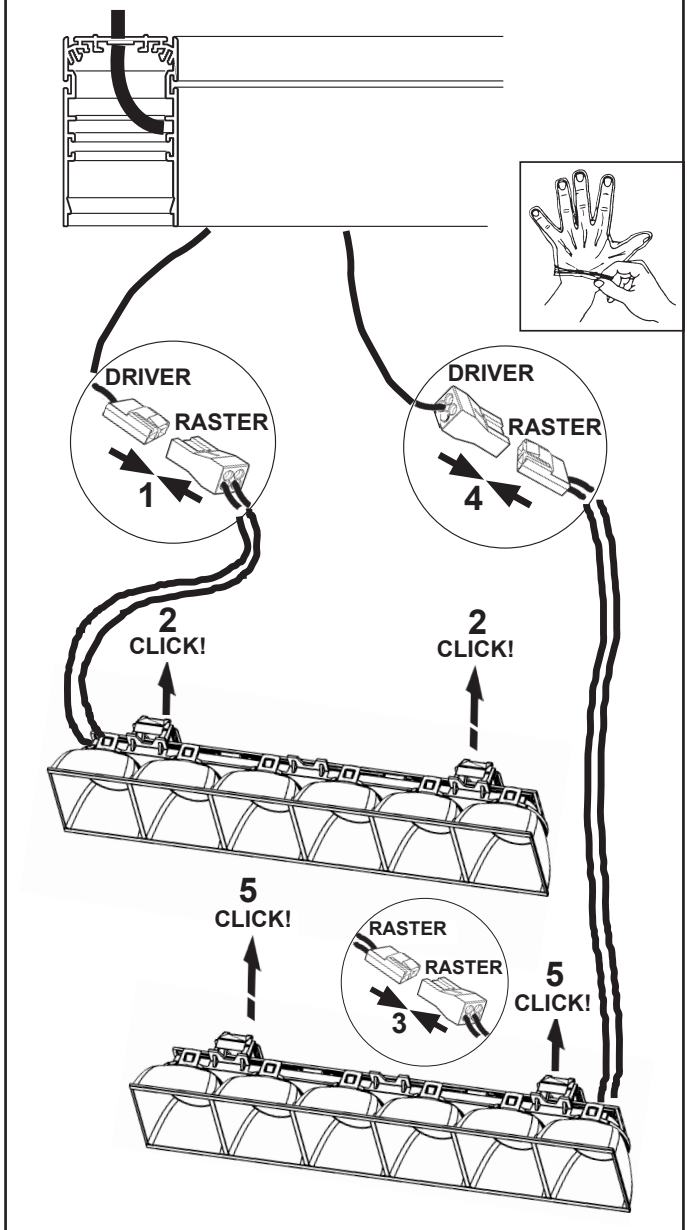

DOWN version UP/DOWN version MONOCROMATIC

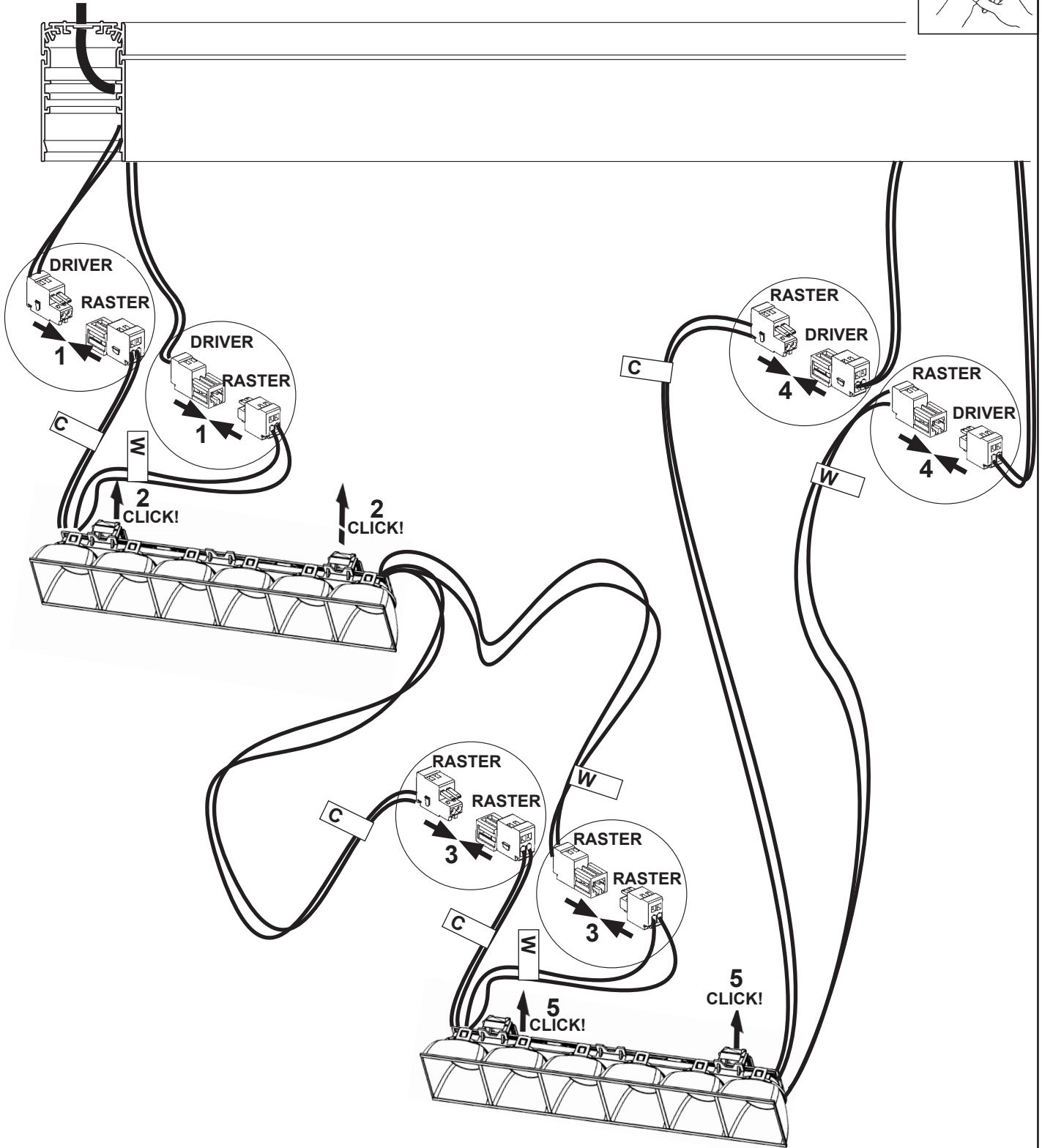
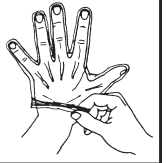

UP/DOWN version
TUNABLE WHITE

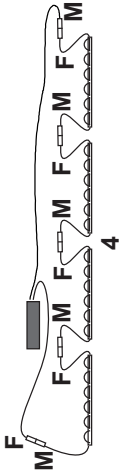
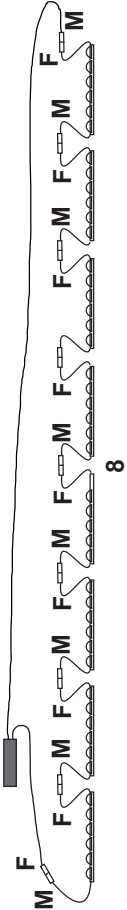
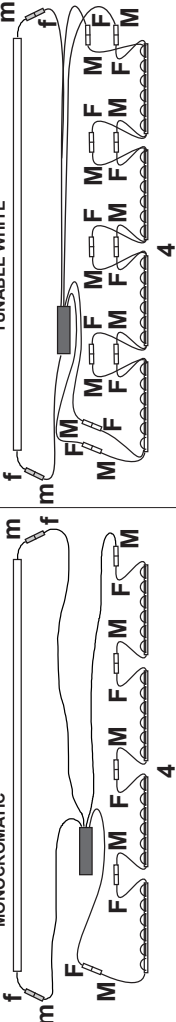
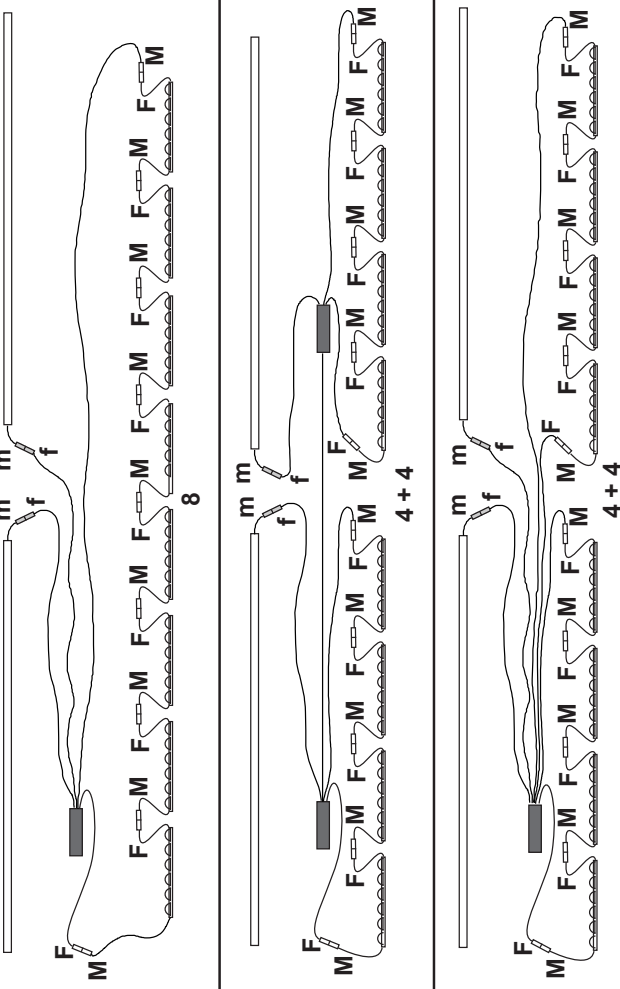

	 L (mm)	RASTER CONFIGURATION
DOWN version	1192 2384	 
UP/DOWN version	1192 2384	 
	<p> RASTER ART. QX89 - QX90 - QX91 - QX92 - QX93 - QX94 - QX95 QX96 - QX97 - QX98 - QX99 - QY00 - QY01 - QY02 QY03 - QY04 - R526 - R527 - R528 - R529 - R530 R531 - R532 - R533 - R534 - R535 - R536 - R537 R538 - R539 - R540 - R541 QY18 - QY19 - QY20 - QY21 - QY22 - QY23 QY24 - QY25 - R555 - R556 - R557 - R558 R559 - R560 - R561 - R562 MONOCROMATIC QY05 - QY06 - QY07 - QY08 - QY09 - QY10 - QY11 QY12 - QY14 - QY15 - QY16 - QY17 R542 - R543 - R544 - R545 - R546 - R547 - R548 R549 - R551 - R552 - R553 - R554 TUNABLE WHITE QY13 - R550 QY26 - QY28 - QY30 - QY32 R563 - R565 - R567 - R569 QY27 - QY29 - QY31 - QY33 R564 - R566 - R568 - R570 QY34 - QY35 - QY36 - QY37 R571 - R572 - R573 - R574 </p>	

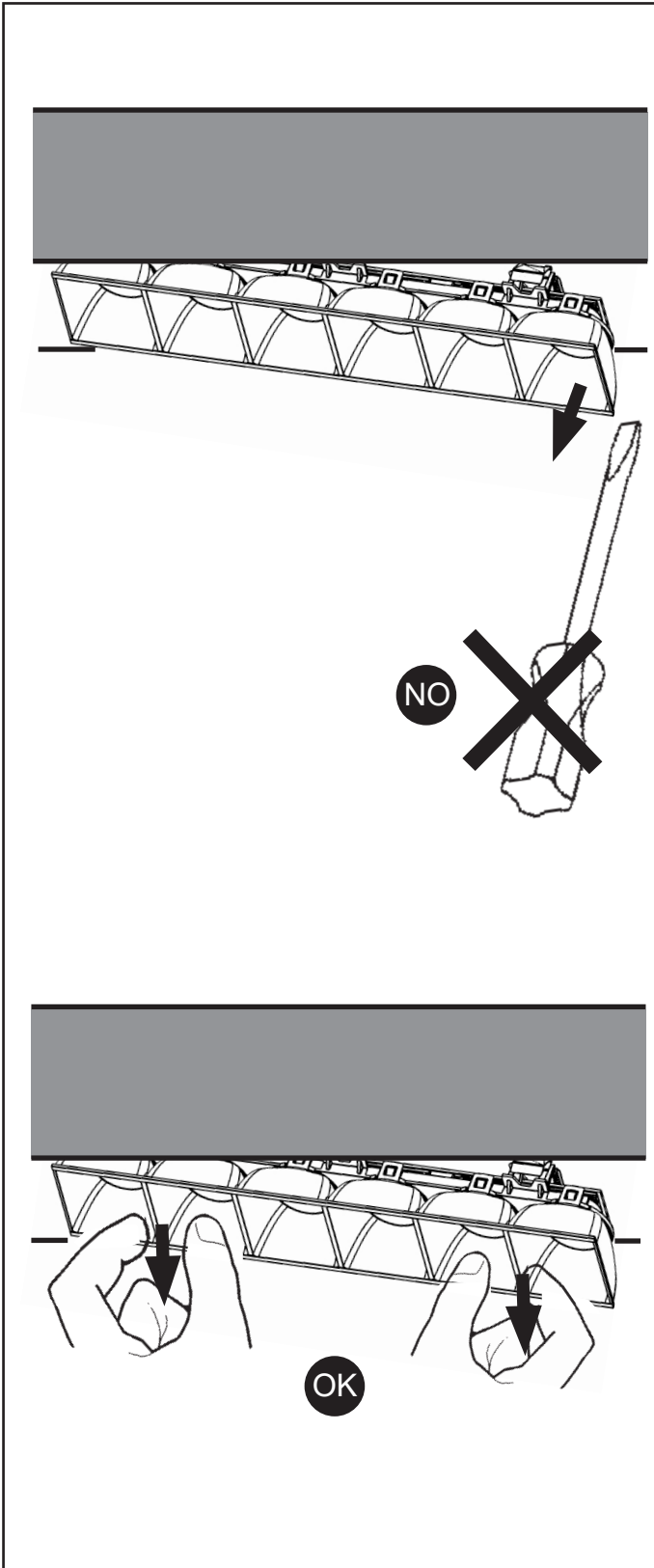
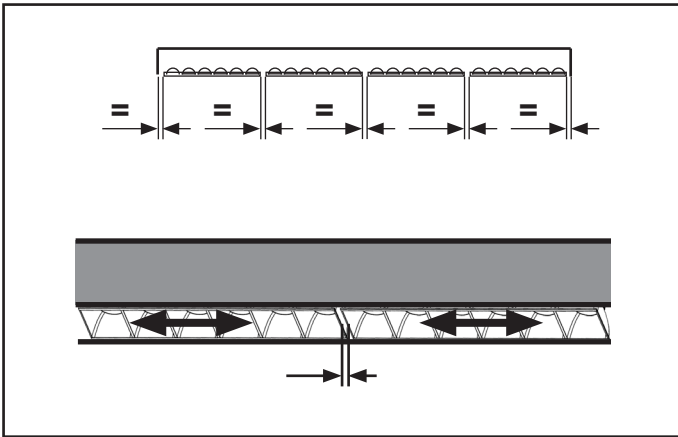

- IT** N.B.: Per l'eventuale pulizia non utilizzare acqua o solventi vari, usare esclusivamente panni morbidi asciutti.
- EN** N.B.: When cleaning, do not use water or any type of solvent. Use only soft dry cloths.
- FR** N.B.: En cas de nettoyage, n'utiliser ni eau ni solvants en général, n'utiliser que des chiffons doux et secs.
- DE** N.B.: Zur eventuellen Reinigung weder Wasser noch Lösungsmittel, sondern ausschließlich ein weiches, trockenes Tuch verwenden.
- NL** N.B.: Gebruik voor het sohoonmaken geen water of oplosmiddelen, maar uitsluitend zachte stofdoeken.
- ES** NOTA: Para la limpieza eventual no usar agua ni solventes de cualquier género, sino exclusivamente un pano suave y seco.
- DA** N.B.: Ved rengøring skal man undgå brug af vand eller forskellige opløsningsmidler. Brug udelukkende en tør, blød klud.
- NO** N.B.: For en eventuell rengjøring, ikke benytt vann eller ymse løsemidler, bruk kun tørre, myke kluter.
- SV** OBS! Använd inte vatten eller diverse lösningsmedel vid eventuell rengöring. Använd endast mjuka och torra trasor.
- RU** ПРИМЕЧАНИЕ: При необходимости произвести чистку не используйте воду или различные растворители, а исключительно сухие мягкие тряпки.
- ZH** 注意：不要用水或任何类型的溶剂进行清洗。只能使用干燥的软布。

- IT** N.B.: Per la sostituzione del LED contattare l'azienda iGuzzini.
- EN** N.B.: For information on LED replacement please contact iGuzzini.
- FR** N.B.: Pour procéder au remplacement de la LED, adressez-vous à la société iGuzzini.
- DE** Ñ.B.: Bezüglich des Austausches der LED kontaktieren Sie bitte die Firma iGuzzini.
- NL** N.B.: Voor het vervangen van de LED neemt u contact op met het bedrijf iGuzzini.
- ES** NOTA: Para sustituir el LED llame a la empresa iGuzzini.
- DA** N.B.: For udskiftning af lysdioden, skal man kontakte iGuzzini.
- NO** N.B.: For informasjon om skifte av LED, vennligst ta kontakt med iGuzzini.
- SV** OBS! För byte av lysdioden, kontakta företaget iGuzzini.
- RU** ПРИМЕЧАНИЕ: Для замены СИДов обращайтесь в компанию iGuzzini.
- ZH** 注意：如需LED更换的信息，请联系iGuzzini。

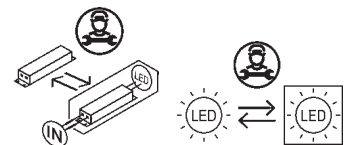

2.510.670.02 IS15971/03 iGuzzini		fattore di potenza power factor facteur de puissance Leistungsfaktor vermogensfactor factor de potencia effektfaktor effektfaktor фактор мощности 功率因数	corrente assorbita absorbed current courant absorbé Stromaufnahme stroomopname corriente absorbida absorberet strøm absorbert strøm tillförd ström поглощаемая мощность 电源电流
ART.	λ	A	
R526.D8 - R528.D8 - R530.D8 - R532.D8	>0,9	0,07	
R542.D8 - R544.D8 - R546.D8 - R548.D8	>0,9	0,09	
QX89 - QX91 - QX93 - QX95	>0,95	0,09	
R526.83 - R528.83 - R530.83 - R532.83 R550.D8	>0,9	0,1	
R555.D8 - R557.D8 - R559.D8 - R561.D8	>0,95	0,12	
QX90 - QX92 - QX94 - QX96 - R527 R529 - R531 - R533	>0,95	0,13	
QY05 - QY07 - QY09 - QY11	>0,95	0,14	
QY13	>0,9	0,15	
R542.83 - R544.83 - R546.83 - R548.83	>0,95	0,15	
QY18 - QY20 - QY22 - QY24	>0,95	0,16	
R550.83 - R563.D8 - R565.D8 - R567.D8 R569.D8	>0,95	0,17	
R555.83 - R557.83 - R559.83 - R561.83	>0,95	0,2	
QY06 - QY08 - QY10 - QY12 - R543 - R545 R547 - R549	>0,95	0,21	
QY14 - QY15 - QY16 - QY17 - R551 R552 - R553 - R554	>0,95	0,22	
QY19 - QY21 - QY23 - QY25 - R556 R558 - R560 - R562	>0,95	0,26	
QY26 - QY28 - QY30 - QY32	>0,95	0,27	
R563.83 - R565.83 - R567.83 - R569.83	>0,95	0,3	
QY27 - QY29 - QY31 - QY33 QY34 - QY35 - QY36 - QY37 R564 - R566 - R568 - R570 R571 - R572 - R573 - R574	>0,95	0,42	

2.510.670.02 IS15971/03 iGuzzini		fattore di potenza power factor facteur de puissance Leistungsfaktor vermogensfactor factor de potencia effektfaktor effektfaktor фактор мощности 功率因数	corrente assorbita absorbed current courant absorbé Stromaufnahme stroomopname corriente absorbida absorberet strøm absorbert strøm tillförd ström поглощаемая мощность 电源电流
ART.	λ	A	
R526.D8 - R528.D8 - R530.D8 - R532.D8	>0,9	0,07	
R542.D8 - R544.D8 - R546.D8 - R548.D8	>0,9	0,09	
QX89 - QX91 - QX93 - QX95	>0,95	0,09	
R526.83 - R528.83 - R530.83 - R532.83 R550.D8	>0,9	0,1	
R555.D8 - R557.D8 - R559.D8 - R561.D8	>0,95	0,12	
QX90 - QX92 - QX94 - QX96 - R527 R529 - R531 - R533	>0,95	0,13	
QY05 - QY07 - QY09 - QY11	>0,95	0,14	
QY13	>0,9	0,15	
R542.83 - R544.83 - R546.83 - R548.83	>0,95	0,15	
QY18 - QY20 - QY22 - QY24	>0,95	0,16	
R550.83 - R563.D8 - R565.D8 - R567.D8 R569.D8	>0,95	0,17	
R555.83 - R557.83 - R559.83 - R561.83	>0,95	0,2	
QY06 - QY08 - QY10 - QY12 - R543 - R545 R547 - R549	>0,95	0,21	
QY14 - QY15 - QY16 - QY17 - R551 R552 - R553 - R554	>0,95	0,22	
QY19 - QY21 - QY23 - QY25 - R556 R558 - R560 - R562	>0,95	0,26	
QY26 - QY28 - QY30 - QY32	>0,95	0,27	
R563.83 - R565.83 - R567.83 - R569.83	>0,95	0,3	
QY27 - QY29 - QY31 - QY33 QY34 - QY35 - QY36 - QY37 R564 - R566 - R568 - R570 R571 - R572 - R573 - R574	>0,95	0,42	

2.510.670.02 IS15971/03 iGuzzini		fattore di potenza power factor facteur de puissance Leistungsfaktor vermogensfactor factor de potencia effektfaktor effektfaktor фактор мощности 功率因数	corrente assorbita absorbed current courant absorbé Stromaufnahme stroomopname corriente absorbida absorberet strøm absorbert strøm tillförd ström поглощаемая мощность 电源电流
ART.	λ	A	
R526.D8 - R528.D8 - R530.D8 - R532.D8	>0,9	0,07	
R542.D8 - R544.D8 - R546.D8 - R548.D8	>0,9	0,09	
QX89 - QX91 - QX93 - QX95	>0,95	0,09	
R526.83 - R528.83 - R530.83 - R532.83 R550.D8	>0,9	0,1	
R555.D8 - R557.D8 - R559.D8 - R561.D8	>0,95	0,12	
QX90 - QX92 - QX94 - QX96 - R527 R529 - R531 - R533	>0,95	0,13	
QY05 - QY07 - QY09 - QY11	>0,95	0,14	
QY13	>0,9	0,15	
R542.83 - R544.83 - R546.83 - R548.83	>0,95	0,15	
QY18 - QY20 - QY22 - QY24	>0,95	0,16	
R550.83 - R563.D8 - R565.D8 - R567.D8 R569.D8	>0,95	0,17	
R555.83 - R557.83 - R559.83 - R561.83	>0,95	0,2	
QY06 - QY08 - QY10 - QY12 - R543 - R545 R547 - R549	>0,95	0,21	
QY14 - QY15 - QY16 - QY17 - R551 R552 - R553 - R554	>0,95	0,22	
QY19 - QY21 - QY23 - QY25 - R556 R558 - R560 - R562	>0,95	0,26	
QY26 - QY28 - QY30 - QY32	>0,95	0,27	
R563.83 - R565.83 - R567.83 - R569.83	>0,95	0,3	
QY27 - QY29 - QY31 - QY33 QY34 - QY35 - QY36 - QY37 R564 - R566 - R568 - R570 R571 - R572 - R573 - R574	>0,95	0,42	

2.510.670.02 IS15971/03 iGuzzini		fattore di potenza power factor facteur de puissance Leistungsfaktor vermogensfactor factor de potencia effektfaktor effektfaktor фактор мощности 功率因数	corrente assorbita absorbed current courant absorbé Stromaufnahme stroomopname corriente absorbida absorberet strøm absorbert strøm tillförd ström поглощаемая мощность 电源电流
ART.	λ	A	
R526.D8 - R528.D8 - R530.D8 - R532.D8	>0,9	0,07	
R542.D8 - R544.D8 - R546.D8 - R548.D8	>0,9	0,09	
QX89 - QX91 - QX93 - QX95	>0,95	0,09	
R526.83 - R528.83 - R530.83 - R532.83 R550.D8	>0,9	0,1	
R555.D8 - R557.D8 - R559.D8 - R561.D8	>0,95	0,12	
QX90 - QX92 - QX94 - QX96 - R527 R529 - R531 - R533	>0,95	0,13	
QY05 - QY07 - QY09 - QY11	>0,95	0,14	
QY13	>0,9	0,15	
R542.83 - R544.83 - R546.83 - R548.83	>0,95	0,15	
QY18 - QY20 - QY22 - QY24	>0,95	0,16	
R550.83 - R563.D8 - R565.D8 - R567.D8 R569.D8	>0,95	0,17	
R555.83 - R557.83 - R559.83 - R561.83	>0,95	0,2	
QY06 - QY08 - QY10 - QY12 - R543 - R545 R547 - R549	>0,95	0,21	
QY14 - QY15 - QY16 - QY17 - R551 R552 - R553 - R554	>0,95	0,22	
QY19 - QY21 - QY23 - QY25 - R556 R558 - R560 - R562	>0,95	0,26	
QY26 - QY28 - QY30 - QY32	>0,95	0,27	
R563.83 - R565.83 - R567.83 - R569.83	>0,95	0,3	
QY27 - QY29 - QY31 - QY33 QY34 - QY35 - QY36 - QY37 R564 - R566 - R568 - R570 R571 - R572 - R573 - R574	>0,95	0,42	